

SONY®



Table of
contents

Operation
Search

Settings
Search

Index

bloggie™

Handbook Mobile HD Snap Camera

MHS-TS10/TS20/TS20K

How to use this handbook

Click on a button on the right to jump to the corresponding page.
This is convenient when searching for a function you want to view.



← Search for information by function.

← Search for information by operation.

← Search for information in a listing of Settings items.

← Search for information by keyword.

Table of contents

Operation Search

Settings Search

Index

Marks and notations used in this handbook

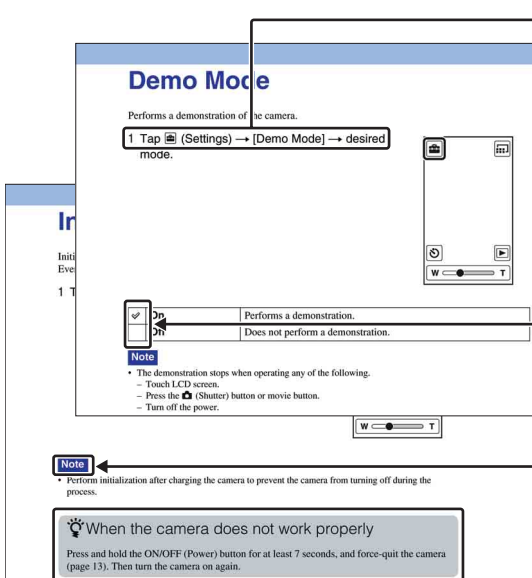

In this handbook, the sequence of operations is shown by arrows (→). Operate the camera in the order indicated. Marks are shown as they appear in the camera's default setting.

The default setting is indicated by ✓.

Indicates cautions and limitations relevant to the correct operation of the camera.

Indicates information that is useful to know.

Notes on using the camera

Internal memory back up

Be sure to make a backup copy to protect your data.

Notes on recording/playback and connection

- Before you start recording, make a trial recording to make sure that the camera is working correctly.
- The camera is neither dust-proof, nor splash-proof, nor water-proof. Read “Precautions” (page 70) before operating the camera.
- Avoid exposing the camera to water. If water enters inside the camera, a malfunction may occur. In some cases, the camera cannot be repaired.
- Do not aim the camera at the sun or other bright light.
- Do not use the camera near a location that generates strong radio waves or emits radiation. Otherwise, the camera may not properly record or play back images.
- Using the camera in sandy or dusty locations may cause malfunctions.
- If moisture condensation occurs, remove it before using the camera (page 70).
- Do not shake or strike the camera. It may cause a malfunction and you may not be able to record images. Furthermore, the recording media may become unusable or image data may be damaged.
- When connecting your camera to another device with a cable, be sure to insert the connector plug in the correct way. Pushing the plug forcibly into the terminal will damage the terminal and may result in a malfunction of your camera.
- Playback of movies other than those shot, edited or composed on this camera is not guaranteed.

On camera's temperature

The camera may get warm due to continuous use, but it is not a malfunction.

On the overheat protection

Depending on the camera and battery temperature, you may be unable to record movies or the power may turn off automatically to protect the camera. A message will be displayed on the LCD screen before the power turns off or you can no longer record movies.

Notes on the battery pack

- The battery pack is built into the camera. Charge the camera before using for the first time.
- You can charge the battery pack even if it is not completely discharged. In addition, even if the battery pack is not fully charged, you can use the partially charged capacity of the battery pack as is.
- For details on the usable battery pack, see page 69.

Notes on the LCD screen and lens

- The LCD screen is manufactured using extremely high-precision technology so over 99.99% of the pixels are operational for effective use. However, some tiny black and/or bright dots (white, red, blue or green) may appear on the LCD screen. These dots are a normal result of the manufacturing process and do not affect the recording.

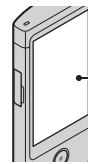

Black, white, red, blue or green dots

- Exposing the LCD screen or the lens to direct sunlight for long periods may cause malfunctions. Be careful when placing the camera near a window or outdoors.
- Do not press against the LCD screen. The screen may be discolored and that may cause a malfunction.
- Images may trail across on the LCD screen in a cold location. This is not a malfunction.

On image data compatibility

- This camera supports “MP4 format” as movie file format. Therefore, movies recorded by this camera cannot be played on devices that do not support “MP4 format”.
- This camera does not support “AVCHD format” and therefore is not compatible with the playback and recording of movies in “AVCHD format” like a Digital HD Video camera recorder.
- Still images recorded by this camera are compressed/recorded in JPEG format. The file extension is “.JPG”.
- The camera conforms with DCF (Design rule for Camera File system) universal standard established by JEITA (Japan Electronics and Information Technology Industries Association).
- Sony does not guarantee that the camera will play back images recorded or edited with other equipment, or that other equipment will play back images recorded with the camera.

Warning on copyright

Television programs, films, videotapes, and other materials may be copyrighted. Unauthorized recording of such materials may be contrary to the provisions of the copyright laws.

No compensation for damaged content or recording failure

Sony cannot compensate for failure to record or loss or damage of recorded content due to a malfunction of the camera or recording media, etc.

The images used in this handbook

- The images used as examples in this handbook are reproduced images, and are not actual images shot using the camera.
- Design and specifications are subject to change without notice.

Notes on playing back movies on other devices

The camera is compatible with MPEG-4 AVC/H.264 Main Profile for HD (high definition) image quality recording. Therefore, you cannot play back images recorded with HD (high definition) image quality on the camera with the devices which are not compatible with the MPEG-4 AVC/H.264.

Life with “Bloggie”

Capture your life

At a party

Record still images at maximum 12M (4128 × 3096) and movies at maximum 1920 × 1080 30p full high-vision (page 36, 37). Also, you can record still images during movie recording (page 31).



During a walk

Take compact “Bloggie” with you anywhere, anytime. Take it out, and record casually.

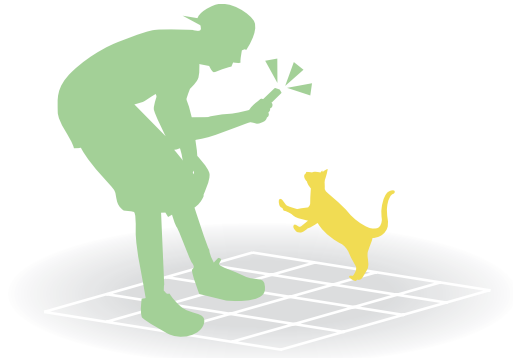

On a trip

Attach the 360 Video Lens to “Bloggie” and shoot exciting 360-degree panoramic images of the world around you. Enjoy 360-degree panoramic images by playing back with the Bloggie Software pre-loaded on the internal memory (page 34). (MHS-TS20K only)

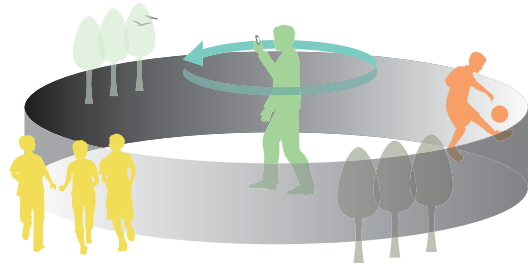

Table of contents

Operation Search

Settings Search

Index

Share your life



Connect to TV

Connect your “Bloggie” to a TV with an HDMI cable (sold separately), and enjoy images on the big screen (page 60).

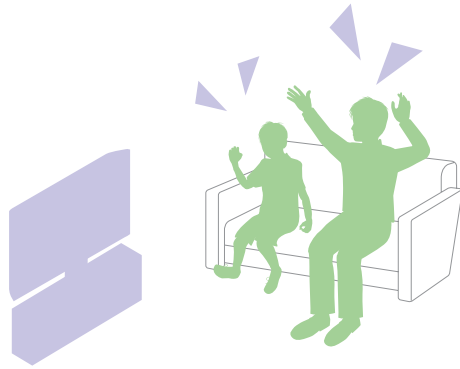
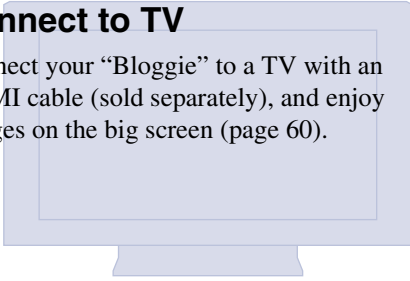

Import and upload captured moments

You can upload images easily and intuitively, using the Bloggie Software pre-loaded on the internal memory (page 24, 50).

You can also choose the images and the sharing site to upload in advance (Share it Later) (page 43).

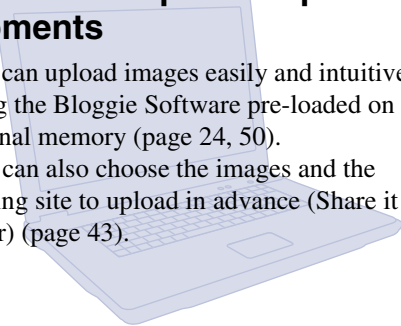

Table of contents

Notes on using the camera

How to use this handbook	2
Notes on using the camera	3
Life with “Blogger”	5
Operation Search	10
Settings Search	11
Identifying parts	13
List of buttons/icons displayed on the screen	14
How to hold the camera	16
How to use the touch panel	18

Getting started

Checking the accessories supplied	20
Charging the camera	21
Installing the software (Windows)	24
Setting the language and clock	26

Shooting

Shooting (Still images)	28
Shooting (Movies)	30
Zoom	32
Self-Timer	33
Shooting 360 Video images (MHS-TS20K only)	34
Photo Size	36
Movie Size	38

Viewing

Viewing.....	39
Playback zoom.....	41
Delete.....	42
Share it Later.....	43
Volume control	45

Computer

Recommended computer environment.....	46
Using the Bloggie Software (Windows).....	48
Importing images to a computer.....	49
Uploading images to a media service	50

Settings

Setting items	11
---------------------	----

TV

Viewing images on a TV	60
------------------------------	----

Troubleshooting

Troubleshooting	62
Warning indicators and messages	66

Others

Number of still images and recordable time of movies.....	68
Built-in battery pack.....	69
Precautions	70
Specifications	71

Index

Index	73
-------------	----

Operation Search

Table of
contents

Operation
Search

Settings
Search

Index

Shooting still images	Shooting (Still images).....	28
Shooting movies	Shooting (Movies)	30
Changing image size	Photo Size	36
	Movie Size	38
Deleting images	Delete.....	42
	Format	58
Displaying enlarged images	Playback zoom.....	41
Changing clock settings	Date & Time Setting.....	59
Initializing settings	Initialize.....	55
Viewing on TVs	Connecting with an HDMI cable (sold separately)	60
Mark the images to upload	Share it Later	43
Shooting a 360-degree view (MHS-TS20K only)	360 Video Lens	34

Settings Search

Setting items

In the table below, ✓ indicates settings that can be changed, while – indicates settings that cannot be changed.

Items	Shooting mode	Playback mode
Protect	–	✓
Beep	✓	✓
Language Setting	✓	✓
Demo Mode	✓	✓
Initialize	✓	✓
HDMI Output	✓	✓
LUN Settings	✓	✓
Format	✓	✓
Date & Time Setting	✓	✓

How to set items

1 Press the ON/OFF (Power) button.

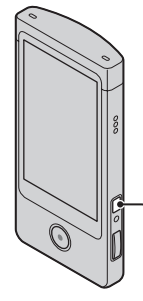

ON/OFF (Power) button

2 Tap  (Settings).

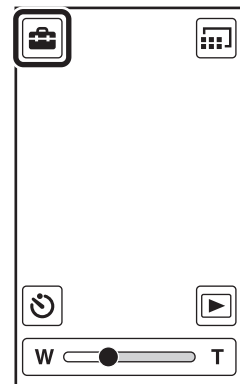

3 Tap the items.

The displayed items scroll by dragging the LCD screen up and down with your finger.

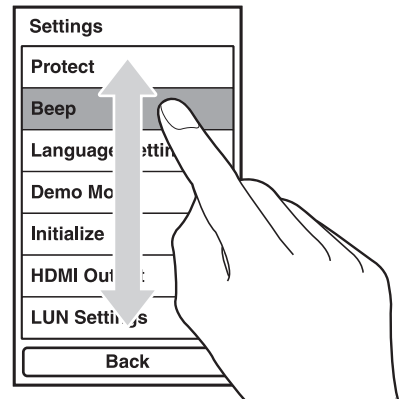



4 Tap the desired mode.

5 Tap [Back].

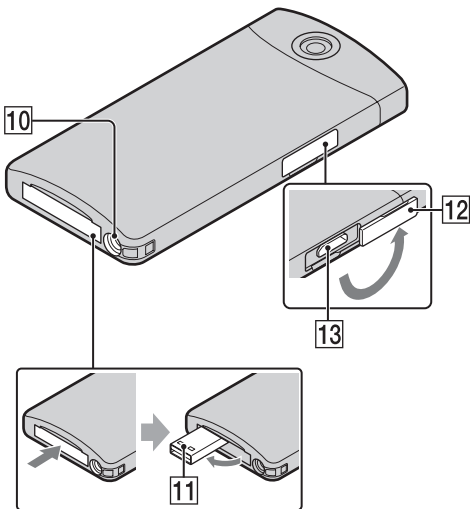
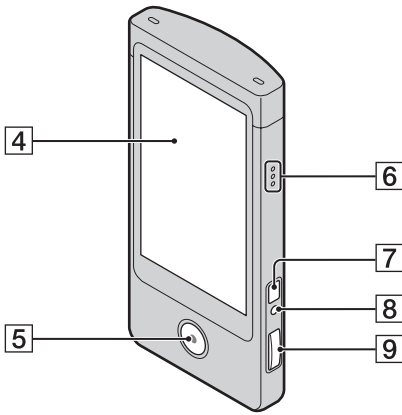
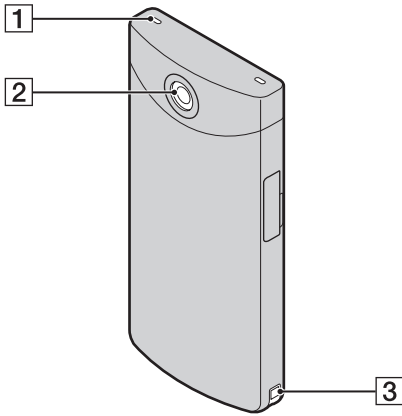
Identifying parts



- 1 Speaker
- 2 Lens
- 3 Hook for wrist strap
- 4 LCD screen/Touch panel
- 5 Movie button
- 6 Microphone
- 7 ON/OFF (Power) button
 - Press and hold the ON/OFF (Power) button for at least 7 seconds to force-quit the camera.
- 8 Charge lamp
- 9  (Shutter) button
- 10 Tripod receptacle
- 11  (USB) jack
- 12 Jack cover
- 13 HDMI OUT jack (60)

List of buttons/icons displayed on the screen

Buttons and icons are displayed on the screen to indicate the camera status.

When in standby for shooting

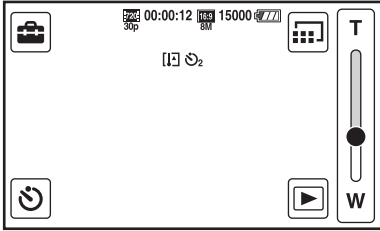

When shooting movies

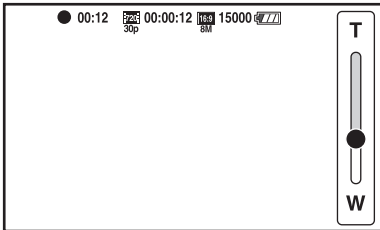

When playing back

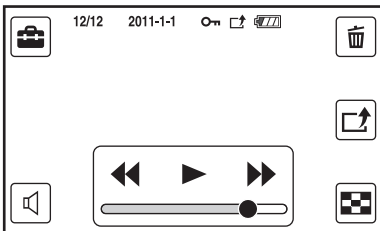

Buttons

Display	Indication
	Settings
	Zoom scaling
	Self-Timer
	Switching image size
	Playback
	Fast rewind/playback/fast forward
	Index
	Delete
	Share it later
	Adjusting volume
	Volume

Icons

Display	Indication
	Battery remaining
	Low battery warning
	Photo Size (aspect ratio/resolution)
	Movie Size (resolution vertical shooting/frame rate)
	Self-timer
15000	Number of recordable still images
	AE/AF lock
00:00:12	Recordable time
0:12	Recording time (m:s)
2011-1-1 9:30 AM	Recorded date/time of the playback image
	During movie recording
	Share it later

Display	Indication
⊖	Protect
[H]	Overheating warning
00:00:12	Counter

Notes

- Indicators and their positions are approximate and differ from what you actually see.
- The screen display shifts both horizontally and vertically depending on the camera aspect.
- The screen display disappears automatically after about 4 seconds. You can change display/ nondisplay by tapping the LCD screen.

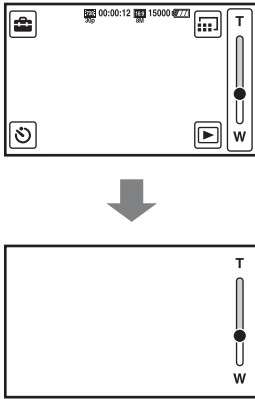

How to hold the camera

- Be careful not to block the lens or microphone with your finger when shooting.

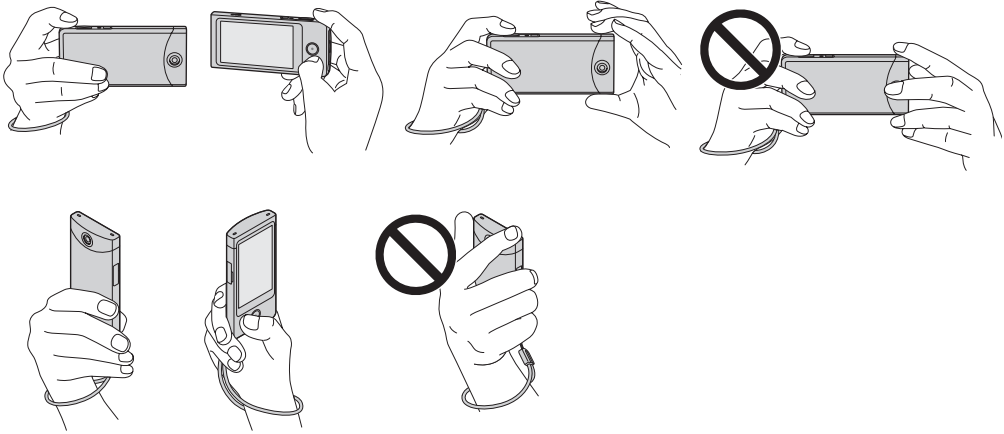

- Do not hold the USB jack.



- Attach the strap and place your hand through its loop to prevent the camera from damage by being dropped.

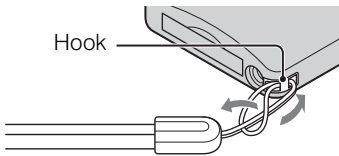

 When you shoot movies holding the camera vertically

Portrait images are recorded. Black bands appear on the left and right of the screen during playback on TV or computer. This is useful when shooting portrait objects.

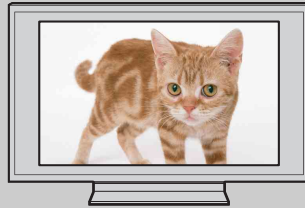

How to use the touch panel

You can operate the camera by tapping the buttons on the LCD screen or dragging the screen.

Note

- Do not operate with a sharp-pointed object, such as pen or finger nail.

Select the items (Tap)

Lightly touch the buttons or items on the screen with your finger.

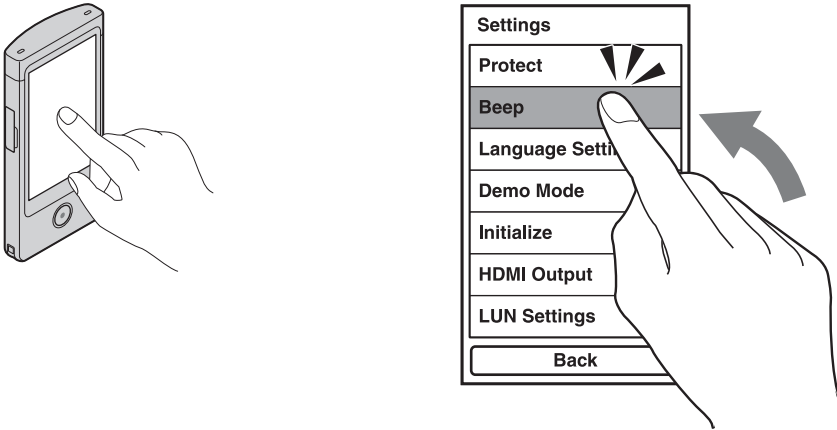

Scroll the screen (Drag)

Touch and slide the screen with your finger.

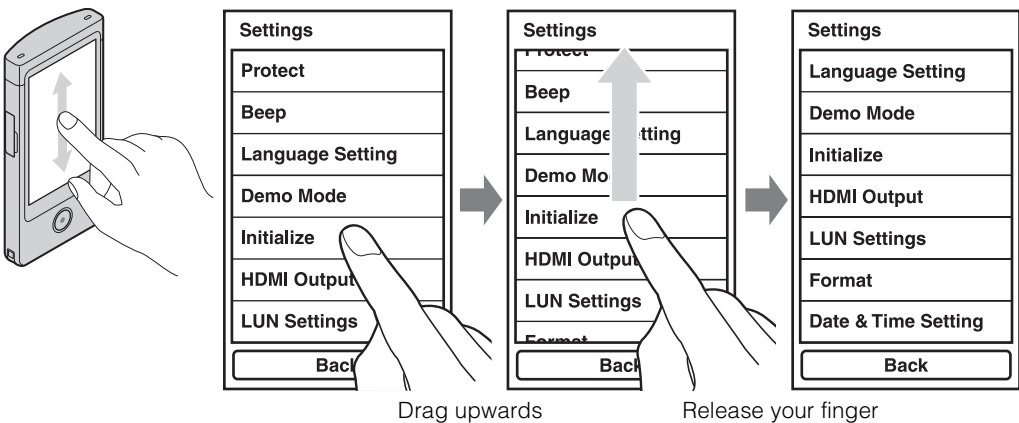

Display the next screen quickly (Flick)

Drag the screen quickly. To stop the screen, tap with your finger.

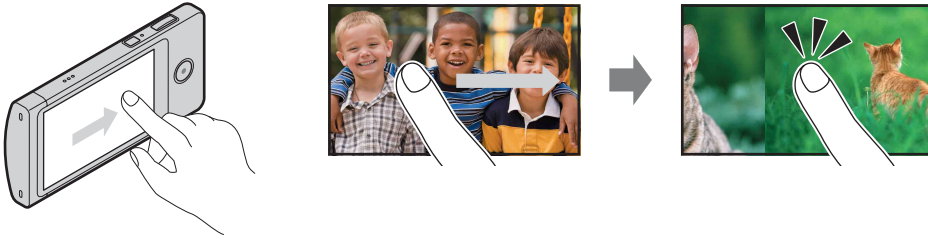

Table of contents

Operation Search

Settings Search

Index

Checking the accessories supplied

- USB connection support cable (1)



- 360 Video Lens VCL-BPP2 (1)/360 Video Lens case (1)
(MHS-TS20K only)



- Wrist strap (1)
- Software (page 24, 48)
The following contents are included in the internal memory of this camera.
 - Bloggie Software (application software)
 - Bloggie Handbook (this manual)
- Instruction Manual (1)
- Important Notice (1)

Charging the camera

The camera's battery is continuously recharged whenever the camera is connected to a running computer.

- 1 Press the ON/OFF (Power) button to turn off the camera.

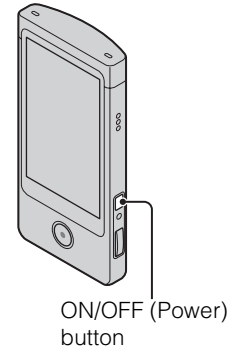

- 2 Push the "PUSH" part at the bottom of the camera.

The USB jack comes out as shown in the illustration.

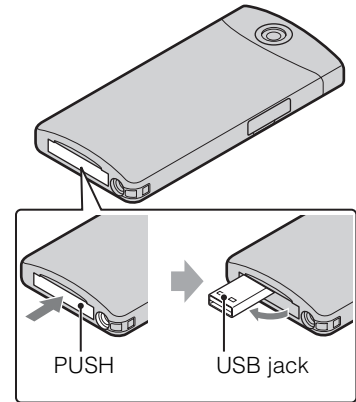

- 3 Connect the camera to the computer that is turned on with the USB connection support cable (supplied).

The charge lamp lights up in orange, and charging starts. When the charge lamp turns off, charging is finished.

- The charge lamp may turn off when the temperature is outside of the recommended operating temperature (10°C to 30°C (50°F to 86°F)).

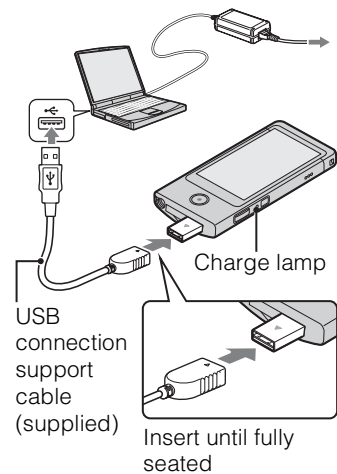

4 When charging is finished, delete the USB connection between the camera and computer.

- Install Bloggie Software (pre-loaded on the internal memory) after completing the procedure above.

Notes

- While the camera is connected to a computer, you cannot operate the camera. Be sure to disconnect the camera before operation.
- Do not apply force to the camera, when you connect the camera to a computer. This may cause damage to the camera or the computer.
- When you connect the camera to a notebook computer that is not connected to an AC power source, the battery of the notebook computer may be depleted rapidly. Do not leave the camera connected to the computer for a long time.
- Charging the battery or the connection with customized or hand-built computers is not guaranteed. Depending on the type of USB device used, charging may not function properly.
- If you do not intend to use the camera for an extended period, charge the camera once every 6 to 12 months to maintain battery performance.

Deleting the USB connection

Perform the procedures from step 1 to 3 below before:

- Disconnecting the USB connection support cable.
- Turning off the camera.

- 1 Double-click the disconnect icon on the tasktray.
- 2 Click  (USB Mass Storage Device) → [Stop].
- 3 Confirm the device on the confirmation window, then click [OK].

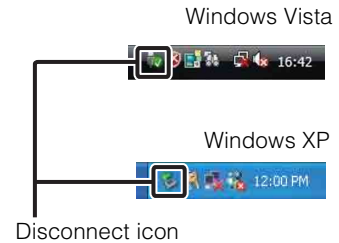

Note

- Drag and drop the drive icon to the “Trash” icon beforehand when you use a Macintosh computer, and the camera is disconnected from the computer.

To retract the USB jack

Push the USB jack back in the direction of the arrow until it clicks.

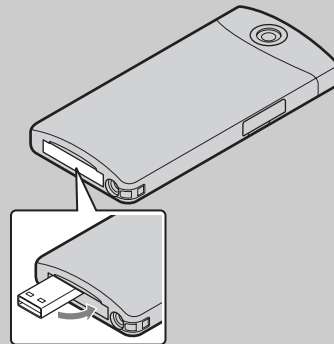

💡 How long does it take to charge the camera?

Charging time

Full charge time
Approx. 200 min.

- Time required to charge a fully depleted battery at a temperature of 25°C (77°F). Charging may take longer under certain circumstances or conditions.

💡 How long can I record or play back images?

Standard battery life

Recording time* ¹	
Continuous recording time* ²	Approx. 120 min.
Typical recording time* ³	Approx. 70 min.

Playback time
Approx. 150 min.

- *¹ Recording time is the time when you set image size to [1280×720 30p].
- *² Continuous recording time shows the approximate time available of a fully charged battery pack. Continuous recording of movies is possible for approximately 29 minutes. Also, recording stops automatically to prevent the file size from exceeding 2 GB.
- *³ Typical recording time shows the approximate time available of a fully charged battery pack when you repeat recording start/stop, turning the power on/off and zooming.

💡 Checking the remaining battery charge

A remaining charge indicator appears on the upper right of the LCD screen.

High       Low

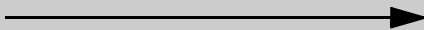

- The displayed battery remaining indicator may not be correct under certain circumstances.
- If the camera is running on battery power and you do not operate the camera for about 5 minutes, the camera turns off automatically to prevent wearing down the battery (Auto power off function).
- The Language/Clock Setting screen appears when the camera is turned on for the first time (page 26).
- It takes about one minute until the correct battery remaining indicator appears.

Installing the software (Windows)

You can do the following using the Bloggie Software (pre-loaded on the internal memory).

- Import images shot with the camera to a computer, and play back.
- Upload images to a network service.

1 Press the ON/OFF (Power) button to turn on the camera.

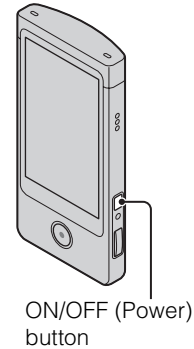

2 Push the “PUSH” part at the bottom of the camera.

The USB jack comes out as shown in the illustration.

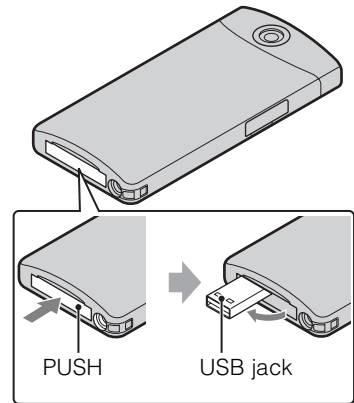

3 Connect the camera to the computer that is turned on with the USB connection support cable (supplied).

When the USB connection is completed, [Mass Storage] appears on the LCD screen of the camera.

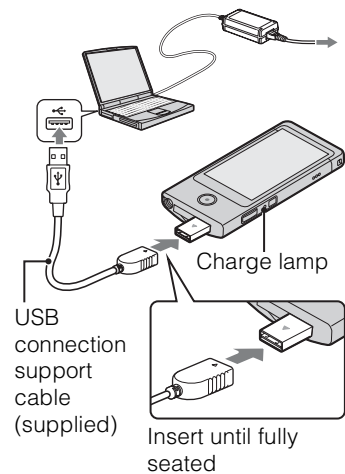

4 Activate the installer.

Windows 7

- 1 Click [Open folder to view files] on the AutoPlay screen.

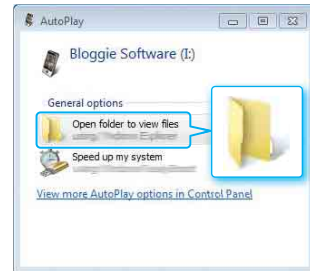

- 2 Double-click "Setup_Bloggie.exe" in the folder.

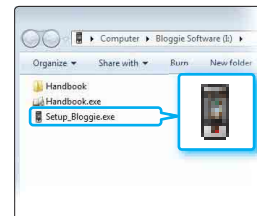

Windows Vista/Windows XP

- 1 Click [Setup Bloggie Software] on the AutoPlay screen.



- If the AutoPlay screen does not appear, click [Start] → [Computer] (in Windows XP, [My Computer]), then double-click [Bloggie Software] → "Setup_Bloggie.exe".

- 5 Click [Install], and follow the instructions on the screen to complete the installation.

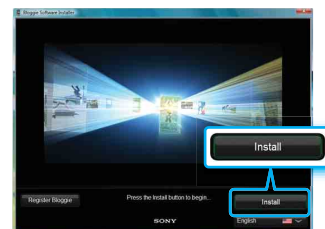

- 6 Delete the USB connection between the camera and computer after the installation is completed (page 22).

- For details on the Bloggie Software, see page 48.

Notes

- If you turn on or restart the computer while the camera is connected to the computer, the camera may malfunction. In this case, press and hold the ON/OFF (Power) button for at least 7 seconds, and force-quit the camera. Disconnect the camera from the computer before turn on or restart the computer.
- Even if you delete files such as "Setup_Bloggie.exe" in the [Bloggie Software] folder, the recording capacity of the camera does not increase.

Setting the language and clock

- 1 Press the ON/OFF (Power) button.

The camera is turned on.

The demonstration movie plays back when you turn on the camera for the first time.

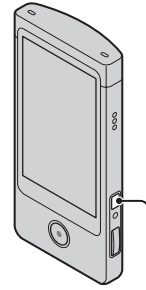

ON/OFF (Power) button

- 2 Select the desired language, then tap [Next].
- 3 Select the desired date display format, then tap [Next].

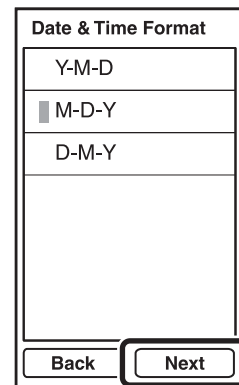

- 4 Select Daylight Savings [On]/[Off], then tap [Next].
- 5 Scroll each item up or down to set the desired date and time, and tap [OK].

Midnight is indicated as 12:00 AM, and noon as 12:00 PM.

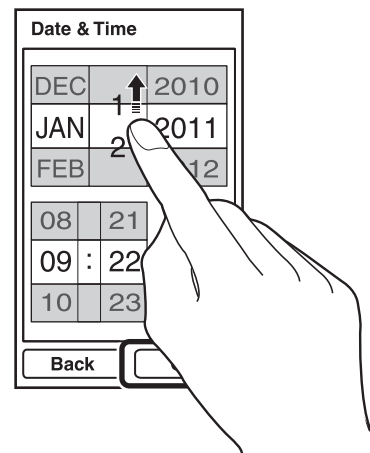



To set the date and time again

Tap  (Settings) and select [Date & Time Setting] (page 59).

Table of
contents

Operation
Search

Settings
Search

Index

Shooting (Still images)

1 Press the ON/OFF (Power) button.

ON/OFF (Power) button

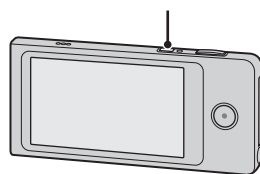

2 Compose the shot.

Be sure not to place fingers on the lens.

Touch and hold T on the T/W (zoom) bar to zoom in,
W to zoom out.

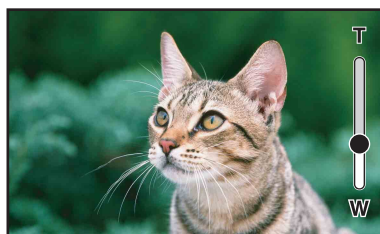
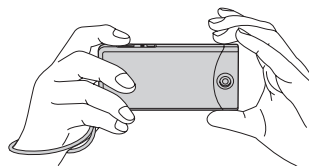

3 Press the  (Shutter) button halfway down.

When the image is in focus, a beep sounds and the ● indicator (AE/AF lock) lights on the top of the display.

AE/AF lock indicator

 (Shutter) button

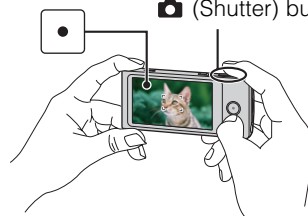

4 Press the  (Shutter) button fully down.



If you shoot a still image of a subject that is difficult to focus on

- The shortest shooting distance is approximately 10 cm (4 inches).
- If the camera cannot focus on a subject automatically, the AE/AF lock indicator changes to slow flashing and the beep does not sound. Recompose the shot.
- Focusing may be difficult in the following situations:
 - It is dark and the subject is distant.
 - The contrast between the subject and the background is poor.
 - The subject is seen through glass.
 - The subject is moving quickly.
 - There is reflective light or shiny surfaces.
 - The subject is flashing.
 - The subject is backlit.



When shooting portrait

- When the camera detects faces, the white frames appear, and the focus and exposure are adjusted to the faces automatically.
- The frames turn green when the faces are in focus by pressing the  (Shutter) button half way down.
- The camera may not detect faces depending on the shooting condition.

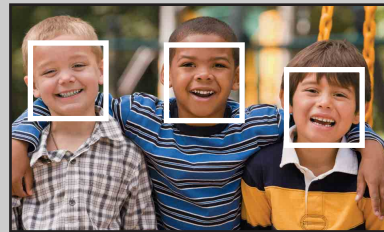

Shooting (Movies)

1 Press the ON/OFF (Power) button.

ON/OFF (Power) button

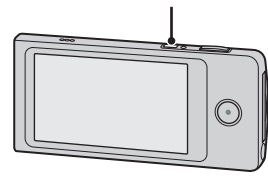

2 Compose the shot.

Be sure not to place fingers on the lens.

Touch and hold T on the T/W (zoom) bar to zoom in,
W to zoom out.

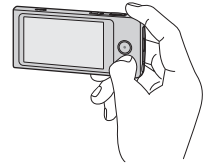

3 Press the movie button.

To finish shooting the movie, press the movie button again.

Movie button



Notes

- Continuous recording is possible for approximately 29 minutes.
- The maximum size of a single movie file is approximately 2 GB. Recording stops before 29 minutes if the file size reaches approximately 2 GB during movie recording.

💡 To shoot still images during movie recording

- Press the  (Shutter) button fully down during movie recording.
- The recorded still image appears small on the LCD screen of the camera.



- The image sizes are as follows, depending on the movie size.

– 1920 × 1080 30p:  (1920 × 1080)

– 1280 × 720 30p/60p:  (1280 × 720)

💡 What is the recording method of this camera?

For MPEG-4 AVC/H.264, the camera supports high definition images with an effective total number of scanning lines of 1080 or 720. The number of recorded image pixel is 1920 × 1080 or 1280 × 720, approximately 30 or 60 frames per second, and the image is recorded in progressive mode.

- MPEG: Moving Picture Experts Group
- AVC: Advanced Video Codec

MPEG-4 AVC/H.264 is a standard of video camera, which uses highly efficient image compression encoding technology to record HD (high definition) images. Compared with the existing image compression encoding technology, MPEG-4 AVC/H.264 is able to compress images even more effectively.

Zoom

You can enlarge the image when shooting. The camera's zoom function can enlarge images up to 4x.

1 Touch and hold T or W.

Touch and hold T to zoom in, W to zoom out.

T side



W side



Notes

- Only Digital zoom is available with this camera.
- You may not be able to zoom in or out images smoothly when using zoom function.
- Image quality decreases as the images are digitally processed.



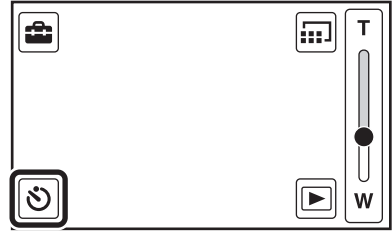

Self-Timer

- 1 Tap  (Self-Timer) on the shooting standby screen.

Tap the LCD screen when the screen display is not shown.



- 2 Tap the desired mode.

<input checked="" type="checkbox"/>	 OFF (Off)	Does not use the self-timer.
<input type="checkbox"/>	 2 (2sec)	Sets the 2-second delay self-timer. When you press the  (Shutter) button or movie button, a self-timer icon flashes, and after rapid beep sounds are heard, the camera will shoot.
<input type="checkbox"/>	 10 (10sec)	Sets the 10-second delay self-timer.

Shooting 360 Video images (MHS-TS20K only)

By attaching the supplied 360 Video Lens to the camera, you can shoot 360-degree images of the area around the camera.

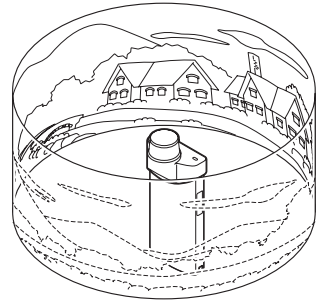

1 Take out the 360 Video Lens from its case.

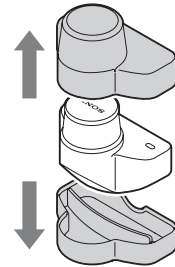

2 Press the ON/OFF (Power) button.

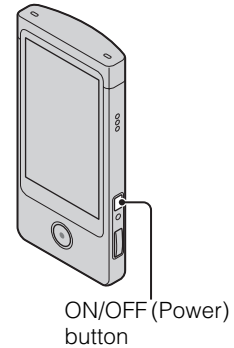

3 Attach the 360 Video Lens to the camera in the direction shown in the illustration.

- The camera shifts to the “360 Video” mode automatically, and the ring-shaped image appears on the LCD screen.

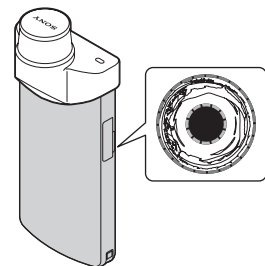

4 Start shooting (page 28, 30).

Notes

- Do not attach or remove the 360 Video Lens during shooting.
- The still image size is fixed to 8M (16:9), and the movie size is fixed to 1920 × 1080 30p.
- When you attach the 360 Video Lens to the camera, you cannot operate zooming or settings.
- Do not hold the camera by the 360 Video Lens only.

To place the camera vertically

Attach the bottom part of the 360 Video Lens case to the bottom of the camera.

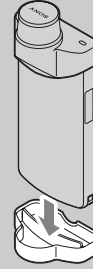

To remove the 360 Video Lens

Pull the 360 Video Lens in the opposite direction of when attaching.

Viewing 360 Video images

You can play back 360 Video images on the computer using the Bloggie Software. For details on the installation of the Bloggie Software, see page 24.

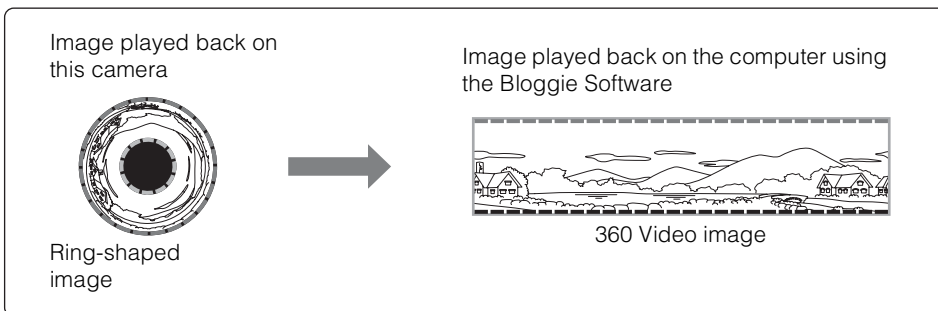

Notes

- You cannot view converted 360 Video images using only the camera.
- When playing back converted 360 Video images, the resolution of the played back images is lower than that of normal images.

Photo Size





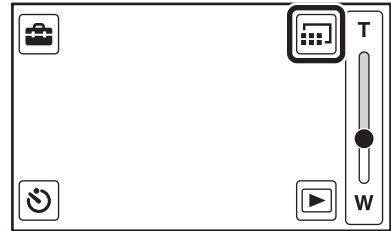

The photo size determines the size of the image file that is recorded when you take an image. The larger the photo size, the more detail will be reproduced when the image is printed on large-format paper. The smaller the photo size, the more images can be recorded.

1 Tap  (Switching image size) on the shooting standby screen.

Tap the LCD screen when the screen display is not shown.





2 Tap the desired size from [Photo Size].

	Photo Size	Usage guidelines	No. of images	Printing
	 (4128×3096) 12M	For prints up to A3+ size	Less 	Fine 
✓	 (3840×2160) 8M	For viewing on a high-definition TV, and for prints up to A4 size	↕	↕
	 (1920×1080) 2M	For viewing on a high-definition TV	More 	Rough 

Note

- When you print still images recorded with 16:9 aspect ratio, both edges may be cut off.

 When you select  (4128 × 3096)

The aspect ratio switches to 4:3 when shooting images.



💡 On “image quality” and “image size”

A digital image is made up of a collection of small dots called pixels. If it contains a large number of pixels, the image becomes large, it takes up more memory, and the image is displayed in fine detail. “Image size” is shown by the number of pixels. Although you cannot see the differences on the screen of the camera, the fine detail and data processing time differ when the image is printed or displayed on a computer screen.

Description of the pixels and the image size

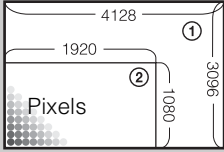

- ① Image size: 12M
 $4128 \text{ pixels} \times 3096 \text{ pixels} = 12,780,288 \text{ pixels}$
- ② Image size: 2M
 $1920 \text{ pixels} \times 1080 \text{ pixels} = 2,073,600 \text{ pixels}$

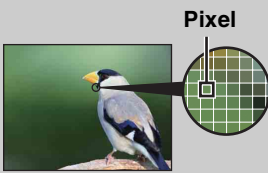

Many pixels
(Fine image quality and large file size)



Few pixels
(Rough image quality but small file size)

Movie Size

The larger the movie size, the higher the movie quality.



The movies shot with the camera will be recorded in MPEG-4 AVC/H.264 Main Profile, approximately 30 or 60 frames per second, Progressive, AAC LC, “MP4 format”.

- 1 Tap  (Switching image size) on the shooting standby screen.

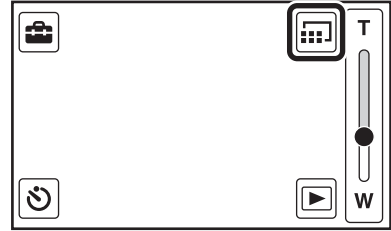
Tap the LCD screen when the screen display is not shown.



- 2 Tap the desired size from [Movie Size].

	Movie Size	Usage guidelines
	 (1920×1080 30p) 30p	Shoots HD (high definition) quality movies in sizes suited for display on computer or high definition TV
	 (1280×720 60p) 60p	Shoots the rapidly moving action scenes such as sports smoothly with HD (high definition) quality
✓	 (1280×720 30p) 30p	Shoots HD (high definition) quality movies in sizes suited for display on computer

Progressive playback

The camera supports progressive mode*, which is used in computers, and therefore is suited for playing back images on computers.

* The progressive mode is a type of movie recording method, which reads out all image pixels at once.

Viewing

- 1 Tap  (Playback) to switch to playback mode.

The index screen appears.

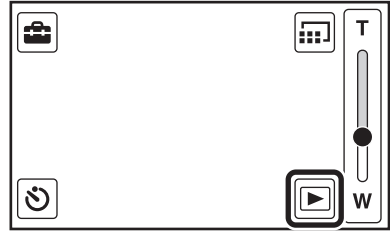

- 2 Select an image and tap.

A single movie plays back when an image is selected.

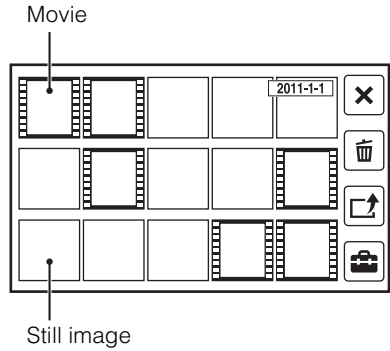

To show previous/next images

Drag your finger in the direction of the arrows.
You can send multiple images at one time by flicking.

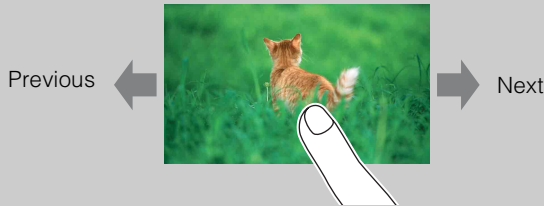

Fast forward/Fast rewind the movie

Tap  /  / .

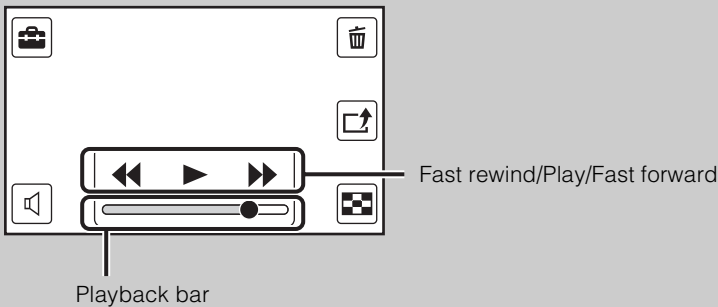

To go back to shooting mode

Do one of the following:

- Tap  on the index screen.

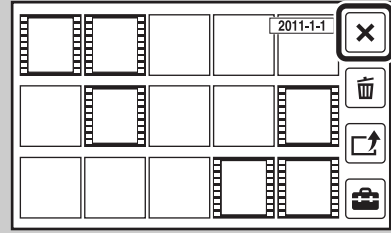

- Press the  (Shutter) button or movie button.

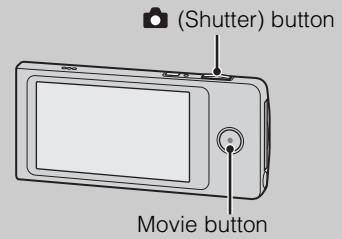

To go back to the index screen

Tap .

Playback zoom

Enlarges the played back still images.

- 1 Tap  (Playback) to switch to playback mode.
- 2 Select the still image and tap.
- 3 Double-tap the part you want to enlarge.

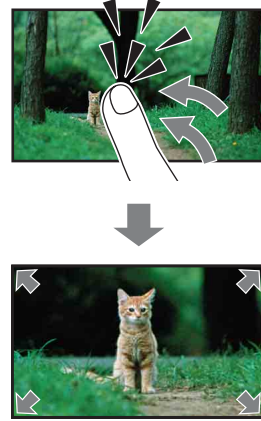

- 4 Adjust the magnification and the part to enlarge.

Each double-tap on the LCD screen enlarges the image up to 8 times its original size.

Drag the image to change the part to enlarge.



To cancel playback zoom, tap .

Note

- You cannot operate playback zoom when an HDMI cable (sold separately) is connected.

Delete

Allows you to select unwanted images for deletion.

- 1 Tap  (Playback) to switch to playback mode.
- 2 Tap  (Delete) on the index screen.

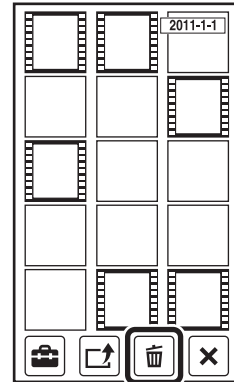

- 3 Tap images you want to delete.

Repeat the above step until there are no more images to be deleted.

Select an image with a mark again to release the mark.

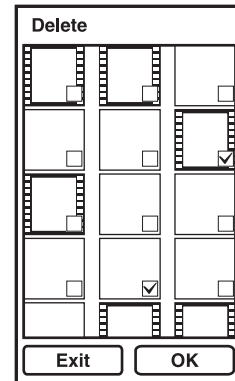



- 4 Tap [OK] → [OK].

 To delete images during playback

Tap  (Delete) → [OK] in single-image mode.

Share it Later

You can choose images and the sharing site to upload in advance.

- 1 Tap  (Playback) to switch to playback mode.
- 2 Tap  (Share it Later) on the index screen.

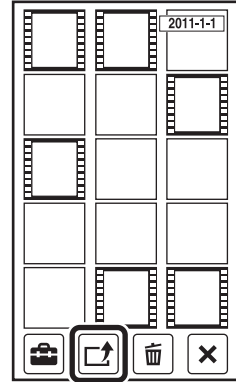

- 3 Tap images you want to upload.

Repeat the above step until there are no more images to be uploaded.

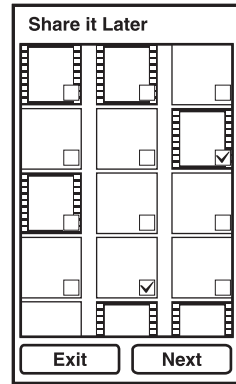

- 4 Tap [Next].

- 5 Select and tap the sharing site to upload from the share list, and tap [OK].

For information on how to upload images, see page 50.

Notes

- You cannot create the share list with the camera. Use Bloggie Software to create.
- The maximum number of share lists the camera can display is 14.



To share images during playback

Tap  (Share it Later) → The sharing site you upload images → [OK] in single-image mode.







To cancel sharing

Tap  (Share it Later) → Release the ✓ mark on the sharing site → [OK] during playback of the image you want to cancel sharing.

Volume control

You can adjust the volume for playback movies.

- 1 Tap  (Playback) to switch to playback mode.
- 2 Select a movie and tap.
- 3 Tap  (Volume control).
Tap the LCD screen when the screen display is not shown.

- 4 Touch and hold  to increase,  to decrease the volume.

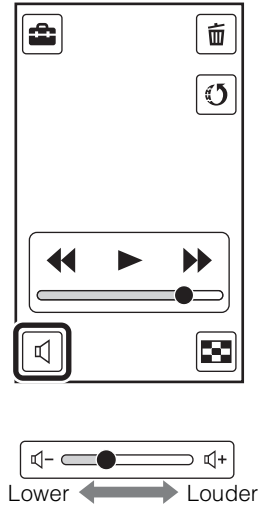

Recommended computer environment

Windows

The following computer environment is recommended when using the Bloggie Software, and importing images via a USB connection.

OS (pre-installed)	Microsoft Windows XP* ¹ SP3/Windows Vista* ² SP1/Windows 7
Others	CPU: Intel Core Duo 1.66 GHz or faster, Intel Core 2 Duo 1.20 GHz or faster Memory: 1 GB or more Hard Disk: Disk space required for installation: approximately 200 MB Display: 1,024 × 768 dots or more

*¹ 64-bit editions and Starter (Edition) are not supported.

*² Starter (Edition) is not supported.

Macintosh

Macintosh is not supported by the Bloggie Software (pre-loaded on the internal memory). The following computer environment is recommended when importing images via a USB connection.

OS (pre-installed)	USB Connection: Mac OS X (v10.3 to v10.6)
---------------------------	--

Notes

- Operation is not assured in an environment based on an upgrade of the operating systems described above or in a multi-boot environment.
- If you connect two or more USB devices to a single computer at the same time, some devices, including the camera, may not operate, depending on the types of USB devices you are using.
- Connecting the camera using a USB interface that is compatible with Hi-Speed USB (USB 2.0 compliant) allows advanced transfer (high speed transfer), as the camera is compatible with Hi-Speed USB (USB 2.0 compliant).
- When your computer resumes activity from suspend or sleep mode, communication between the camera and your computer may not recover at the same time.

Note on playback of movie files (MPEG-4 AVC/H.264)

To play back and edit movie files (MPEG-4 AVC/H.264) recorded by the camera on your computer, you need to install the software compatible with MPEG-4 AVC/H.264 or the Bloggie Software.

- Even in a PC environment where operations are guaranteed, images may not play back smoothly due to dropped frames, etc. Note that the imported image itself is not affected.
- If you are using a notebook PC, be sure to use the PC with the AC adaptor plugged in. Sometimes normal operations are not possible due to the power savings function of the PC.

Note

- Operations are not guaranteed, even on computers fulfilling the above system requirements. For example, other open or background applications currently running may limit product performance.

Using the Bloggie Software (Windows)

Activating

- 1 Double-click the Bloggie Software (pre-loaded on the internal memory) shortcut icon on the desktop.



Connecting the camera to a computer

If the Bloggie Software is already installed to a computer, Bloggie Software starts automatically.

Importing images to a computer

To connect the camera to your computer, see page 46.

Windows

When using the Bloggie Software

See page 48.

When not using the Bloggie Software

When the AutoPlay Wizard appears after making a USB connection between the camera and a computer, click [Open folder to view files] → [OK] → [DCIM] or [MP_ROOT] → copy the desired images to the computer.

Macintosh

- 1 Connect the camera to your Macintosh computer first. Double-click the newly recognized [BLOGGIE] icon → [DCIM] or [MP_ROOT] → the folder where the images you want to import are stored.
- 2 Drag and drop the image files to the hard disk icon.
The image files are copied to the hard disk.
- 3 Double-click the hard disk icon → the desired image file in the folder containing the copied files.
The image is displayed.

Uploading images to a media service

Windows

- 1 Choose images and the sharing site to upload with the camera in advance (page 43).
- 2 Connect the camera to a computer in which the Bloggie Software (pre-loaded on the internal memory) is already installed.
Bloggie Software starts automatically and the confirmation screen for uploading images appears.

Macintosh

Upload images by following the uploading procedure of the network service.

Notes

- Set [LUN Settings] to [Multi].
- When uploading images over the Internet, the cache may remain in the computer being used depending on the service provider. This is also true when the camera is used for this purpose.

Notes on Bloggie Software (pre-loaded on the internal memory)



In order to use Bloggie Software to enjoy the benefits of the image uploading service or other services (the “services”) provided by these and other websites, you must consent to the following.

- Some websites require registration procedures and/or fees to use their services. In using such services, you must comply with the terms and conditions established by the websites concerned.
- Services may be terminated or changed in accordance with the convenience of the website operators. Sony will not be held responsible for any trouble occurring between the users and third parties or any inconvenience caused to users relating to the utilization of the services inclusive of the termination of or changes to such services.
- To view a website, you will be redirected to it by the Sony server. There may be times when you cannot access the website because of server maintenance or for other reasons.
- If the operation of the Sony server is to be terminated, you will be notified of the termination ahead of time on Sony’s website, etc.
- The URLs to which you are redirected by the Sony server and other information may be recorded for the purposes of improving Sony’s future products and services. However, no personal data will be recorded on such occasions.

Protect



Protects recorded images against accidental erasure.

The  mark is displayed when playing back registered images.

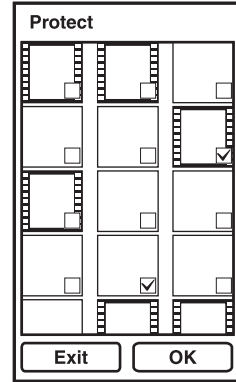

- 1 Tap  (Playback) to switch to playback mode.
- 2 Tap  (Settings) → [Protect] on the index screen.

In single-image mode, protect is completed in step 2.



- 3 Tap images you want to protect.
Select an image with a  mark to release the  mark.
- 4 Tap [OK].

To cancel the protection

Tap  (Settings) → [Protect] during image playback as the same procedure to protect it. The  indicator disappears, and the protection is released.

Beep

Sets the sound for when you operate the camera.

1 Tap  (Settings) → [Beep] → desired mode.

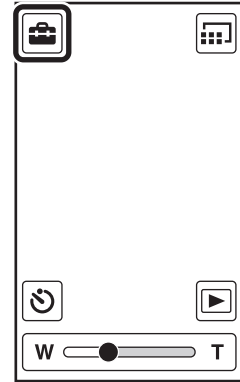

<input checked="" type="checkbox"/>	On	Turns on the beep sound when you press the  (Shutter) button or movie button.
<input type="checkbox"/>	Off	Turns off the beep sound.

Language Setting

Selects the language to be used in the menu items, warnings and messages.

- 1 Tap  (Settings) → [Language Setting] → desired language.

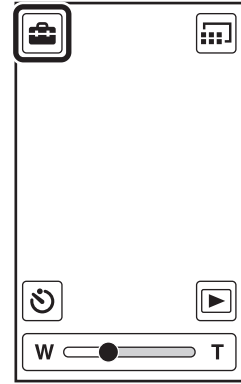

Table of contents

Operation Search

Settings Search

Index

Demo Mode

Performs a demonstration of the camera.

- 1 Tap  (Settings) → [Demo Mode] → desired mode.

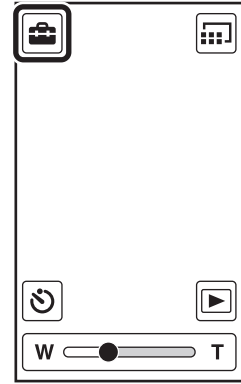

<input checked="" type="checkbox"/>	On	Performs a demonstration.
<input type="checkbox"/>	Off	Does not perform a demonstration.

Note

- The demonstration stops when operating any of the following.
 - Touch LCD screen.
 - Press the  (Shutter) button or movie button.
 - Turn off the power.

Initialize

Initializes the setting to the default setting.
Even if you execute this function, the images are retained.

1 Tap  (Settings) → [Initialize] → [OK].

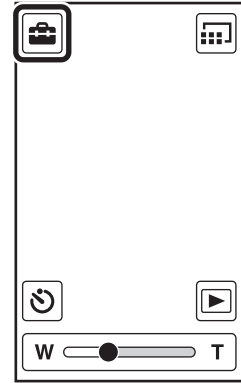

Note

- Perform initialization after charging the camera to prevent the camera from turning off during the process.

When the camera does not work properly

Press and hold the ON/OFF (Power) button for at least 7 seconds, and force-quit the camera (page 13). Then turn the camera on again.

HDMI Output

Selects the type of signal to be output to a TV from the HDMI OUT jack. If images are not displayed on the TV clearly, changing the setting may improve the display.

- 1 Tap  (Settings) → [HDMI Output] → desired mode.

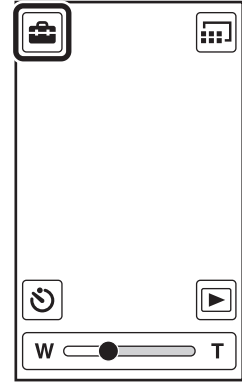

<input checked="" type="checkbox"/>	60Hz	Outputs with 60Hz.
<input type="checkbox"/>	50Hz	Outputs with 50Hz.

LUN Settings

Sets the display method for the recording media displayed on a computer screen or other monitor when the camera is connected with a computer or AV component using a USB connection.

1 Tap  (Settings) → [LUN Settings] → desired mode.

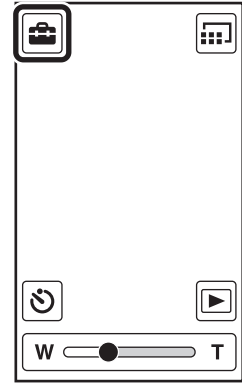

<input checked="" type="checkbox"/>	Multi	Select this setting when you connect the camera to a computer.
<input type="checkbox"/>	Single	Select this setting in cases where the images are not displayed when the camera is connected to a device other than a computer.

Format

Formats the internal memory.

1 Tap  (Settings) → [Format] → [OK].

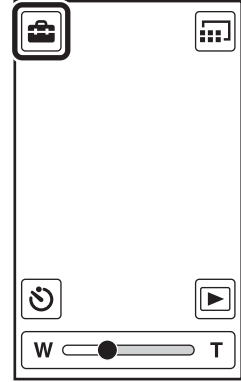

Note

- Note that formatting permanently erases all data including even protected images.

Date & Time Setting

Sets the date and time again.

1 Tap  (Settings) → [Date & Time Setting].

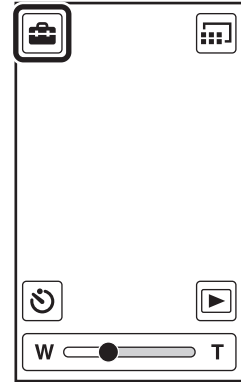

2 Tap the items you want to set.

Date & Time Format	Selects the date and time display format.
Daylight Savings	Pushes forward an hour.
Date & Time	Sets the date and time (page 26).

Viewing images on a TV

Connect the camera to a TV which has an HDMI terminal with an HDMI cable (sold separately). Refer also to the instruction manuals of the TV.

- 1 Turn off both the camera and the TV.
- 2 Open the jack cover and connect the camera to the TV with the HDMI cable (sold separately).

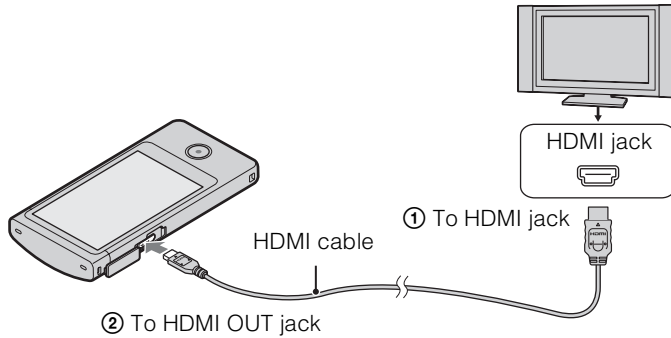

- 3 Turn on the camera.
- 4 Turn on the TV and set the input.
Images shot with the camera appear on the TV.
- 5 Tap images to play back.

Notes

- Do not connect the output terminal of the camera to that of other devices. This may result in malfunction.
- Some devices may not work properly. Image and sound may not be output.
- Use an HDMI cable with the HDMI logo.

On TV color systems

If you want to view images on a TV screen, you need a TV with an HDMI terminal and an HDMI cable (sold separately). The color system of the TV must match that of the camera. Check the following lists for the TV color system of the country or region where the camera is used, and set [HDMI Output] (page 56).

NTSC system

Bahama Islands, Bolivia, Canada, Central America, Chile, Colombia, Ecuador, Jamaica, Japan, Korea, Mexico, Peru, Surinam, Taiwan, the Philippines, the U.S.A., Venezuela, etc.

PAL system

Australia, Austria, Belgium, China, Croatia, Czech Republic, Denmark, Finland, Germany, Holland, Hong Kong, Hungary, Indonesia, Italy, Kuwait, Malaysia, New Zealand, Norway, Poland, Portugal, Rumania, Singapore, Slovak Republic, Spain, Sweden, Switzerland, Thailand, Turkey, United Kingdom, Viet Nam, etc.

PAL-M system

Brazil

PAL-N system

Argentina, Paraguay, Uruguay

SECAM system

Bulgaria, France, Greece, Guiana, Iran, Iraq, Monaco, Russia, Ukraine, etc.

Table of
contents

Operation
Search

Settings
Search

Index

Troubleshooting

If you experience trouble with the camera, try the following solutions.

1 Check the items on pages 62 to 67.

2 Turn the power off and then on again.

3 Press and hold the ON/OFF (Power) button for at least 7 seconds, and force-quit the camera. Then turn the camera on again (page 13).

4 Consult your Sony dealer or local authorized Sony service facility.

Be aware that by sending the camera for repair, you give consent that the contents of the internal memory, music files may be checked.

Additional information on this product and answers to frequently asked questions can be found at our Customer Support Website.
<http://www.sony.net/>

Battery pack and power

Cannot turn on the camera.

- The battery pack is discharged. Charge the camera.

The power turns off suddenly.

- Depending on the camera and battery temperature, the power may turn off automatically to protect the camera. In this case, a message is displayed on the LCD screen before the power turns off.
- If you do not operate the camera for a certain period of time while the power is on, the camera turns off automatically to prevent wearing down the battery pack. Turn the camera on again.

Battery life is short.

- Charge the battery until the charge lamp disappears.
- You are using the camera in an extremely hot or cold location, or the charging is insufficient. This is not a malfunction.
- If you have not used the camera for a prolonged period, the efficiency of the battery will be improved by repeatedly charging and discharging it.
- When usable battery life becomes half the usual time, even after charging the battery fully, the battery may need to be replaced. Consult your nearest Sony dealer.

Cannot charge the camera.

- Turn off the camera and make the USB connection.
- Disconnect the USB connection support cable, and then reconnect it.
- Use the USB connection support cable (supplied).
- Charge the battery in an ambient temperature of 10°C to 30°C (50°F to 86°F).
- Turn on the computer and connect the camera.
- Release the computer from sleep or hibernation status.
- Connect the camera directly to a computer using the supplied USB connection support cable.
- Connect the camera to a computer with the operating system that is supported by the camera.
- After trying the remedies above, if the problem still persists, press and hold the ON/OFF (Power) button for at least 7 seconds, and force-quit the camera. Then reconnect it to the computer using the supplied USB connection support cable.

The remaining charge indicator is incorrect.

- This phenomenon occurs when you use the camera in an extremely hot or cold location.
- A discrepancy arose between the remaining charge indicator and the actual remaining battery charge. Fully discharge the battery pack once, then charge it to correct the indication.
- The battery pack is dead (page 69). Consult your nearest Sony dealer.

Shooting still images/movies

Cannot record images.

- Check the free capacity of the internal memory. If it is full, delete unnecessary images (page 42).

The date and time are not displayed on the LCD screen.

- While shooting, the date and time are not displayed. They are displayed only during playback.

Cannot insert dates on images.

- The camera does not have a feature for superimposing dates on images.

Dots appear and remain on the screen.

- This is not a malfunction. These dots are not recorded.

Viewing images

Cannot play back images.

- The folder/file name has been changed on your computer.
- Playback on the camera cannot be guaranteed if files contain images processed on a computer, or images shot by another camera.
- The camera is in USB mode. Delete the USB connection (page 22).

The image appears rough right after playback starts.

- This may happen due to image processing. This is not a malfunction.

The image does not appear on the TV.

- Set [HDMI Output] to [60Hz] in NTSC region, [50Hz] in PAL region (page 56).
- Check whether the connection is correct (page 60).

The top and bottom edges of images are trimmed slightly on a connected TV.

- The LCD screen of the camera can display recording images across the entire screen (full pixel display). However, this may cause slight trimming of the top, bottom, right, and left edges of images when played back on a TV that is not compatible with full pixel display.

Black bands appear on the left and right of the screen.

- Black bands appear on the left and right of the screen when viewing movies recorded with the camera held in the vertical position on a TV or a computer. This is not a malfunction.

Deleting

Cannot delete an image.

- Cancel the protection (page 51).

Computers

Your computer does not recognize the camera.

- When the battery level is low, charge the camera.
- Turn on the camera and connect to a computer.
- Use the USB connection support cable (supplied).
- Disconnect the USB connection support cable from both the computer and the camera, and connect it again firmly.
- Disconnect all equipment other than the camera, the keyboard and the mouse from the USB connectors of your computer.
- Connect the camera directly to your computer without passing through a USB hub or other device.
- Set [LUN Settings] to [Multi] (page 57).

Cannot import images.

- Connect the camera and your computer correctly making a USB connection (page 46).
- When you format the internal memory with a computer, you may not be able to import the images to a computer. Format the internal memory with the camera, and shoot (page 58).

After making a USB connection, Bloggie Software does not start automatically.

- Install the Bloggie Software to a computer, and make the USB connection after both the camera and a computer are turned on.

Cannot play back images on your computer.

- Consult the computer or software manufacturer.

The image and sound are interrupted by noise when you view a movie on a computer.

- You are playing back the movie directly from the internal memory. Import the movie to your computer using the Bloggie Software and play it back (page 49).

Others

The camera does not work properly.

- Press and hold the ON/OFF (Power) button for at least 7 seconds, and force-quit the camera. Then turn the camera on again.

The lens gets fogged.

- Moisture condensation has occurred. Turn off the camera and wait about an hour for the moisture to evaporate.

The camera becomes warm when you use it for a long time.

- This is not a malfunction.

The Clock Set screen appears when you turn on the camera.

- Set the date and time again (page 26).

The date or time is incorrect.

- Set the date and time again (page 59).

Warning indicators and messages

If the following messages appear, follow the instructions.



- The battery level is low. Charge the battery pack immediately. Depending on the conditions of use, the indicator may flash even though there are still 5 to 10 minutes of remaining battery time left.

System error

- Turn the power off and then on again.



- If you record movies for an extended period, the camera temperature rises. In this case, stop recording movies.

Camera overheating

Allow it to cool

- The camera temperature has risen. The power may turn off automatically, or you may be unable to record movies. Leave the camera in a cool location until the temperature goes down.

Internal memory error

- Turn the power off and then on again.

Error formatting internal memory

- Format the media again (page 58).

No images

- No images that can be played back have been recorded in the internal memory.

Folder error

- A folder with the same first three digit number already exists on the internal memory (for example: 123MSDCF and 123ABCDE). Format the camera (page 58).

Cannot create more folders

- The folder with a name beginning with “999” exists on the internal memory. Format the camera (page 58).

File error

- An error occurred while the image was playing back.
Playback on the camera cannot be guaranteed if files contain images processed on a computer, or images shot by another camera.

File protected

- Release the protection (page 51).

Image size over limit

- You are playing back an image with size that cannot be played back on the camera.

Maximum number of images already selected

- Up to 100 files can be selected when using [Delete], [Share it Later] and [Protect].

Operation cannot be executed in unsupported files

- Playback zoom cannot be performed on movies.

Invalid operation

- This message appears if you perform an invalid operation.

Number of still images and recordable time of movies

The number of still images and recordable time may vary depending on the shooting conditions.

Still images

(Units: Images)

Size	Capacity	
	(MHS-TS10)	(MHS-TS20/TS20K)
4:3 (12M)	622	1296
16:9 (8M)	799	1665
16:9 (2M)	3528	7343

Notes

- When the number of remaining recordable images is greater than 9,999, the “>9999” indicator appears.
- When images recorded using other cameras are played back on this camera, the display may differ from the actual image size.
- When measuring media capacity, 1 GB equals 1 billion bytes, a portion of which is used for data management.

Movies

The table below shows the approximate maximum recording times. These are the total times for all movie files. Continuous shooting is possible for approximately 29 minutes.

(Units: hour : minute : second)

Size	Capacity	
	(MHS-TS10)	(MHS-TS20/TS20K)
1920×1080 30p	0:40:00 (0:22:00)	1:20:00 (0:47:00)
1280×720 60p	1:20:00 (0:36:00)	2:40:00 (1:25:00)
1280×720 30p	2:00:00 (0:54:00)	4:00:00 (2:00:00)

Notes

- Your camera uses the VBR (Variable Bit Rate) format to automatically adjust image quality to suit the recording scene. This technology causes fluctuations in the recording time of the internal memory. Movies containing quickly moving and complex images are recorded at a higher bit rate, and this reduces the overall recording time.
- The maximum size of a single movie file is approximately 2 GB. Recording stops before 29 minutes if the file size reaches approximately 2 GB during movie recording.
- The number in () is the minimum recording time.
- When continuous shooting ends, the recording stops automatically.

Built-in battery pack

On charging the battery pack

- We recommend charging the battery pack in an ambient temperature of between 10°C to 30°C (50°F to 86°F). The battery pack may not be effectively charged in temperatures outside this range.
- When usable battery life becomes half the usual time, even after charging the battery fully, the battery should be replaced. Consult your nearest Sony dealer.

Effective use of the battery pack

- Battery performance decreases in low temperature surroundings. So in cold places, the operational time of the battery pack is shorter.
- The battery pack will run out quickly if you use the zoom frequently.
- Do not expose the camera to water. The camera is not water-resistant.
- Do not leave the camera in an extremely hot place, such as in a car or under direct sunlight.

How to store the camera

- Even if you do not use the camera for an extended period, fully charge the camera every 6 to 12 months to maintain the camera's function. Also, store the camera in a cool, dry place.

On battery life

- The battery life is limited. Battery capacity decreases over time and through repeated use. If decreased usage time between charges becomes significant, consult your nearest Sony dealer.
- The battery life varies according to how it is stored and the operating conditions and environment in which each battery pack is used.

Precautions

Do not use/store the camera in the following places

- In an extremely hot, cold or humid place
In places such as in a car parked in the sun, the camera body may become deformed and this may cause a malfunction.
- Under direct sunlight or near a heater
The camera body may become discolored or deformed, and this may cause a malfunction.
- In a location subject to rocking vibration
- Near strong magnetic fields
- In sandy or dusty places
Be careful not to let sand or dust get into the camera. This may cause the camera to malfunction, and in some cases may be irreparable.

On carrying

Do not sit down in a chair or other place with the camera in the back pocket of your trousers or skirt, as this may cause malfunction or damage the camera.

On cleaning

Cleaning the LCD screen

Wipe the screen surface with an LCD cleaning kit (sold separately) to remove fingerprints, dust, etc.

Cleaning the lens

Wipe the lens with a soft cloth to remove fingerprints, dust, etc.

Cleaning the camera surface

Clean the camera surface with a soft cloth slightly moistened with water, then wipe the surface with a dry cloth. Do not use any of the following as they may damage the finish or the casing.

- Chemical products such as thinner, benzene, alcohol, disposable cloths, insect repellent, sunscreen or insecticide, etc.
- Do not touch the camera with any of the above on your hand.
- Do not leave the camera in contact with rubber or vinyl for a long time.

On operating temperatures

Your camera is designed for use under the temperatures between 0°C and 40°C (32°F and 104°F). Shooting in extremely cold or hot places that exceed this range is not recommended.

On moisture condensation

If the camera is brought directly from a cold to a warm location, moisture may condense inside or outside the camera. This moisture condensation may cause a malfunction of the camera.

If moisture condensation occurs

Turn off the camera and wait about an hour for the moisture to evaporate.

Note on disposal/transfer

- When using the software pre-loaded on the internal memory, personal information such as IDs and mail addresses may be saved on the internal memory of the camera. Before changing ownership of the camera, or before disposal, delete any personal information.
- Even if you delete data in the internal memory or format the camera, you may not delete data from the internal memory completely. When you dispose of the camera, it is recommended that you destroy the actual body of the camera.

Specifications

Camera

[System]

Image device: 7.35 mm (1/2.5 type) CMOS sensor

Total pixel number of camera:

Approx. 13 011 000 pixels

Effective pixel number of camera:

Approx. 8 294 000 pixels (still image, 16:9),

Approx. 12 780 000 pixels (still image, 4:3),

Approx. 2 073 000 pixels ([1920×1080 30p] movie)

Lens: F2.8

f = 5.3 mm (7/32 inches)

When converted to a 35 mm still camera

For movies: 37 mm (1 1/2 inches) (16:9)

For still images: 32 mm (1 5/16 inches) (4:3)

Exposure control: Automatic exposure

File format:

Still images: JPEG (DCF Ver. 2.0, Exif Ver. 2.3, MPF Baseline) compliant

Movies: MPEG-4 AVC/H.264 (MP4)

Audio: MPEG AAC

Recording media: Internal Memory (MHS-TS10:

Approx. 4 GB, MHS-TS20/TS20K: Approx. 8 GB)

- When measuring media capacity, 1 GB equals 1 billion bytes, a portion of which is used for system management and/or application files.

Available user capacity is as below.

MHS-TS10: Approx. 3.7 GB

MHS-TS20/TS20K: Approx. 7.7 GB

[Input and Output connectors]

HDMI jack: HDMI mini connector

USB jack: type A (built-in)

USB communication: Hi-Speed USB (USB 2.0 compliant)

[LCD screen]

LCD screen: 7.6 cm 3.0 type (16:9) TFT drive

Total number of dots: 288 000 (720 × 400) dots

[Power, general]

Power:

Built-in rechargeable battery pack

USB charging (supplied from the computer by connecting with the supplied USB connection support cable)

Charging time: Approx. 200 mins. (full charge)

(when charging from the USB connector of the computer)

Power consumption (during shooting): 1.7 W

(when the movie image size is [1280×720 30p])

Operating temperature: 0°C to 40°C (32°F to 104°F)

Storage temperature: -20°C to +60°C (-4°F to +140°F)

Dimensions: Approx. 52.0 mm × 107.0 mm ×

15.2 mm (2 1/8 inches × 4 1/4 inches ×

5/8 inches) (W/H/D, excluding protrusions)

Mass: Approx. 125 g (4.4 oz)

Microphone: Monaural

Speaker: Monaural

Design and specifications are subject to change without notice.

Trademarks

- “Bloggie” is a trademark of Sony Corporation.
- 360 Video is a trademark of Sony Corporation.
- HDMI, the HDMI logo and High-Definition Multimedia Interface are trademarks or registered trademarks of HDMI Licensing LLC.



- Microsoft, Windows, Windows Vista and DirectX are either registered trademarks or trademarks of Microsoft Corporation in the United States and/or other countries.
- Macintosh, Mac OS, iMac, iBook, PowerBook, Power Mac and eMac are trademarks or registered trademarks of Apple Inc..
- Intel and Pentium are trademarks or registered trademarks of Intel Corporation.

In addition, system and product names used in this manual are, in general, trademarks or registered trademarks of their respective developers or manufacturers. However, the TM or © marks are not used in all cases in this manual.

Notes on the License

THIS PRODUCT IS LICENSED UNDER THE AVC PATENT PORTFOLIO LICENSE FOR THE PERSONAL AND NON-COMMERCIAL USE OF A CONSUMER TO (i) ENCODE VIDEO IN COMPLIANCE WITH THE AVC STANDARD (“AVC VIDEO”) AND /OR (ii) DECODE AVC VIDEO THAT WAS ENCODED BY A CONSUMER ENGAGED IN A PERSONAL AND NON-COMMERCIAL ACTIVITY AND/OR WAS OBTAINED FROM A VIDEO PROVIDER LICENSED TO PROVIDE AVC VIDEO. NO LICENSE IS GRANTED OR SHALL BE IMPLIED FOR ANY OTHER USE. ADDITIONAL INFORMATION MAY BE OBTAINED FROM MPEG LA, L.L.C. SEE <[HTTP://WWW.MPEGLA.COM](http://www.mpegla.com)>

Index

Numerics

360 Video images34

B

Battery pack69

Beep52

Bloggie Software24, 48

C

Charging21

Clock Settings26

Computer

 Importing images49

 Recommended environment46

 Uploading images50

Connecting

 Computer49

D

Date & Time Setting59

Daylight Savings26, 59

Delete42

Demo Mode54

F

Format58

H

HDMI OUT jack60

HDMI Output56

I

Identifying parts13

Initialize55

Install24

L

Language Setting53

LUN Settings57

M

Macintosh computer46

Movie Size38

N

Number of still images68

O

OS46

P

Photo Size36

Pixel37

Playback zoom41

Protect51

R

Recordable time of movies68

S

Self-Timer33

Settings11

Share it Later43

Shooting

 Movies30

 Still images28

Software24, 48

T

Touch panel18

Troubleshooting62

U

USB21, 24

V

View

 Movies39

 Still images39

Volume control45

W

Warning messages66

Windows computer46

Z

Zoom32

Table of
contents

Operation
Search

Settings
Search

Index