

X58 Pro-E series

MS-7522 (v3.x) Mainboard



msi

Copyright Notice

The material in this document is the intellectual property of MICRO-STAR INTERNATIONAL. We take every care in the preparation of this document, but no guarantee is given as to the correctness of its contents. Our products are under continual improvement and we reserve the right to make changes without notice.

Trademarks

All trademarks are the properties of their respective owners.

- MSI® is registered trademark of Micro-Star Int'l Co.,Ltd.
- NVIDIA® is registered trademark of NVIDIA Corporation.
- ATI® is registered trademark of ATI Technologies, Inc.
- AMD® is registered trademarks of AMD Corporation.
- Intel® is registered trademarks of Intel Corporation.
- Windows® is registered trademarks of Microsoft Corporation.
- AMI® is registered trademark of Advanced Micro Devices, Inc.
- Award® is a registered trademark of Phoenix Technologies Ltd.
- Sound Blaster® is registered trademark of Creative Technology Ltd.
- Realtek® is registered trademark of Realtek Semiconductor Corporation.
- JMicron® is registered trademark of JMicron Technology Corporation.
- Netware® is a registered trademark of Novell, Inc.

Revision History

Revision	Revision History	Date
V3.1	First release for X58 Pro-E	March 2009

Technical Support

If a problem arises with your system and no solution can be obtained from the user's manual, please contact your place of purchase or local distributor. Alternatively, please try the following help resources for further guidance.

- ☐ Visit the MSI website for FAQ, technical guide, BIOS updates, driver updates, and other information: <http://www.msi.com/index.php?func=service>
- ☐ Contact our technical staff at: <http://ocss.msi.com>

Safety Instructions

- Always read the safety instructions carefully.
- Keep this User's Manual for future reference.
- Keep this equipment away from humidity.
- Lay this equipment on a reliable flat surface before setting it up.
- The openings on the enclosure are for air convection hence protects the equipment from overheating. **DO NOT COVER THE OPENINGS.**
- Make sure the voltage of the power source and adjust properly 110/220V before connecting the equipment to the power inlet.
- Place the power cord such a way that people can not step on it. Do not place anything over the power cord.
- Always Unplug the Power Cord before inserting any add-on card or module.
- All cautions and warnings on the equipment should be noted.
- Never pour any liquid into the opening that could damage or cause electrical shock.
- If any of the following situations arises, get the equipment checked by service personnel:
 - The power cord or plug is damaged.
 - Liquid has penetrated into the equipment.
 - The equipment has been exposed to moisture.
 - The equipment does not work well or you can not get it work according to User's Manual.
 - The equipment has dropped and damaged.
 - The equipment has obvious sign of breakage.

DO NOT LEAVE THIS EQUIPMENT IN AN ENVIRONMENT UNCONDITIONED, STORAGE TEMPERATURE ABOVE 600 C (1400F), IT MAY DAMAGE THE EQUIPMENT.

CAUTION: Danger of explosion if battery is incorrectly replaced.

Replace only with the same or equivalent type recommended by the manufacturer.

警告使用者:

這是甲類資訊產品，在居住的環境中使用時，可能會造成無線電干擾，在這種情況下，使用者會被要求採取某些適當的對策。



廢電池請回收

For better environmental protection, waste batteries should be collected separately for recycling special disposal.

FCC-B Radio Frequency Interference Statement

This equipment has been tested and found to comply with the limits for a Class B digital device, pursuant to Part 15 of the FCC Rules. These limits are designed to provide reasonable protection against harmful interference in a residential installation. This equipment generates, uses and can radiate radio frequency energy and, if not installed and used in accordance with the instructions, may cause harmful interference to radio communications. However, there is no guarantee that interference will not occur in a particular installation. If this equipment does cause harmful interference to radio or television reception, which can be determined by turning the equipment off and on, the user is encouraged to try to correct the interference by one or more of the measures listed below.



- Reorient or relocate the receiving antenna.
- Increase the separation between the equipment and receiver.
- Connect the equipment into an outlet on a circuit different from that to which the receiver is connected.
- Consult the dealer or an experienced radio/television technician for help.

Notice 1

The changes or modifications not expressly approved by the party responsible for compliance could void the user's authority to operate the equipment.

Notice 2

Shielded interface cables and A.C. power cord, if any, must be used in order to comply with the emission limits.

OIR LA NOTICE D'INSTALLATION AVANT DE RACCORDER AU RESEAU.



This device complies with Part 15 of the FCC Rules. Operation is subject to the following two conditions:

- 1) this device may not cause harmful interference, and
- 2) this device must accept any interference received, including interference that may cause undesired operation.

WEEE (Waste Electrical and Electronic Equipment) Statement

ENGLISH

To protect the global environment and as an environmentalist, MSI must remind you that...



Under the European Union ("EU") Directive on Waste Electrical and Electronic Equipment, Directive 2002/96/EC, which takes effect on August 13, 2005, products of "electrical and electronic equipment" cannot be discarded as municipal waste anymore and manufacturers of covered electronic equipment will be obligated to take back such products at the end of their useful life. MSI will comply with the product take back requirements at the end of life of MSI-branded products that are sold into the EU. You can return these products to local collection points.

DEUTSCH

Hinweis von MSI zur Erhaltung und Schutz unserer Umwelt

Gemäß der Richtlinie 2002/96/EG über Elektro- und Elektronik-Altgeräte dürfen Elektro- und Elektronik-Altgeräte nicht mehr als kommunale Abfälle entsorgt werden. MSI hat europaweit verschiedene Sammel- und Recyclingunternehmen beauftragt, die in die Europäische Union in Verkehr gebrachten Produkte, am Ende seines Lebenszyklus zurückzunehmen. Bitte entsorgen Sie dieses Produkt zum gegebenen Zeitpunkt ausschliesslich an einer lokalen Altgerätesammelstelle in Ihrer Nähe.

FRANÇAIS

En tant qu'écologiste et afin de protéger l'environnement, MSI tient à rappeler ceci...

Au sujet de la directive européenne (EU) relative aux déchets des équipement électriques et électroniques, directive 2002/96/EC, prenant effet le 13 août 2005, que les produits électriques et électroniques ne peuvent être déposés dans les décharges ou tout simplement mis à la poubelle. Les fabricants de ces équipements seront obligés de récupérer certains produits en fin de vie. MSI prendra en compte cette exigence relative au retour des produits en fin de vie au sein de la communauté européenne. Par conséquent vous pouvez retourner localement ces matériels dans les points de collecte.

РУССКИЙ

Компания MSI предпринимает активные действия по защите окружающей среды, поэтому напоминаем вам, что....

В соответствии с директивой Европейского Союза (ЕС) по предотвращению загрязнения окружающей среды использованным электрическим и электронным оборудованием (директива WEEE 2002/96/ЕС), вступающей в силу 13 августа 2005 года, изделия, относящиеся к электрическому и электронному оборудованию, не могут рассматриваться как бытовой мусор, поэтому производители вышеперечисленного электронного оборудования обязаны принимать его для переработки по окончании срока службы. MSI обязуется соблюдать требования по приему продукции, проданной под маркой MSI на территории ЕС, в переработку по окончании срока службы. Вы можете вернуть эти изделия в специализированные пункты приема.

ESPAÑOL

MSI como empresa comprometida con la protección del medio ambiente, recomienda: Bajo la directiva 2002/96/EC de la Unión Europea en materia de desechos y/o equipos electrónicos, con fecha de rigor desde el 13 de agosto de 2005, los productos clasificados como “eléctricos y equipos electrónicos” no pueden ser depositados en los contenedores habituales de su municipio, los fabricantes de equipos electrónicos, están obligados a hacerse cargo de dichos productos al término de su período de vida. MSI estará comprometido con los términos de recogida de sus productos vendidos en la Unión Europea al final de su período de vida. Usted debe depositar estos productos en el punto limpio establecido por el ayuntamiento de su localidad o entregar a una empresa autorizada para la recogida de estos residuos.

NEDERLANDS

Om het milieu te beschermen, wil MSI u eraan herinneren dat...

De richtlijn van de Europese Unie (EU) met betrekking tot Vervuiling van Electriche en Electronische producten (2002/96/EC), die op 13 Augustus 2005 in zal gaan kunnen niet meer beschouwd worden als vervuiling. Fabrikanten van dit soort producten worden verplicht om producten retour te nemen aan het eind van hun levenscyclus. MSI zal overeenkomstig de richtlijn handelen voor de producten die de merknaam MSI dragen en verkocht zijn in de EU. Deze goederen kunnen geretourneerd worden op lokale inzamelingspunten.

SRPSKI

Da bi zaštitili prirodnu sredinu, i kao preduzeće koje vodi računa o okolini i prirodnoj sredini, MSI mora da vas podesti da...

Po Direktivi Evropske unije (“EU”) o odbačenju eelektronskoj i električnoj opremi, Direktiva 2002/96/EC, koja stupa na snagu od 13. Avgusta 2005, proizvodi koji spadaju pod “elektronsku i električnu opremu” ne mogu više biti odbačeni kao običan otpad i proizvođači ove opreme biće prinuđeni da uzmu natrag ove proizvode na kraju njihovog uobičajenog veka trajanja. MSI će poštovati zahtev o preuzimanju ovakvih proizvoda kojima je istekao vek trajanja, koji imaju MSI oznaku i koji su prodati u EU. Ove proizvode možete vratiti na lokalnim mestima za prikupljanje.

POLSKI

Aby chronić nasze środowisko naturalne oraz jako firma dbająca o ekologię, MSI przypomina, że...

Zgodnie z Dyrektywą Unii Europejskiej (“UE”) dotyczącą odpadów produktów elektrycznych i elektronicznych (Dyrektywa 2002/96/EC), która wchodzi w życie 13 sierpnia 2005, tzw. “produkty oraz wyposażenie elektryczne i elektroniczne” nie mogą być traktowane jako śmieci komunalne, tak więc producenci tych produktów będą zobowiązani do odbierania ich w momencie gdy produkt jest wycofywany z użycia. MSI wypełni wymagania UE, przyjmując produkty (sprzedawane na terenie Unii Europejskiej) wycofywane z użycia. Produkty MSI będzie można zwracać w wyznaczonych punktach zbiorczych.

TÜRKÇE

Çevreci özelliğiyle bilinen MSI dünyada çevreyi korumak için hatırlatır:

Avrupa Birliği (AB) Kararnamesi Elektrik ve Elektronik Malzeme Atığı, 2002/96/EC Kararnamesi altında 13 Ağustos 2005 tarihinden itibaren geçerli olmak üzere, elektrikli ve elektronik malzemeler diğer atıklar gibi çöpe atılmayacak ve bu elektronik cihazların üreticileri, cihazların kullanım süreleri bittikten sonra ürünleri geri toplamakla yükümlü olacaktır. Avrupa Birliği'ne satılan MSI markalı ürünlerin kullanım süreleri bittiğinde MSI ürünlerin geri alınması isteği ile işbirliği içerisinde olacaktır. Ürünlerinizi yerel toplama noktalarına bırakabilirsiniz.

ČESKY

Záleží nám na ochraně životního prostředí - společnost MSI upozorňuje...

Podle směrnice Evropské unie ("EU") o likvidaci elektrických a elektronických výrobků 2002/96/EC platné od 13. srpna 2005 je zakázáno likvidovat "elektrické a elektronické výrobky" v běžném komunálním odpadu a výrobci elektrických výrobků, na které se tato směrnice vztahuje, budou povinni odebírat takové výrobky zpět po skončení jejich životnosti. Společnost MSI splní požadavky na odebírání výrobků značky MSI, prodávaných v zemích EU, po skončení jejich životnosti. Tyto výrobky můžete odevzdat v místních sběrnách.

MAGYAR

Annak érdekében, hogy környezetünket megvédjük, illetve környezetvédőként fellépve az MSI emlékezteti Önt, hogy ...

Az Európai Unió („EU”) 2005. augusztus 13-án hatályba lépő, az elektromos és elektronikus berendezések hulladékairól szóló 2002/96/EK irányelve szerint az elektromos és elektronikus berendezések többé nem kezelhetőek lakossági hulladékként, és az ilyen elektronikus berendezések gyártói kötelessé válnak az ilyen termékek visszavételére azok hasznos élettartama végén. Az MSI betartja a termékvisszavétellel kapcsolatos követelményeket az MSI márkanev alatt az EU-n belül értékesített termékek esetében, azok élettartamának végén. Az ilyen termékeket a legközelebbi gyűjtőhelyre viheti.

ITALIANO

Per proteggere l'ambiente, MSI, da sempre amica della natura, ti ricorda che....

In base alla Direttiva dell'Unione Europea (EU) sullo Smaltimento dei Materiali Elettrici ed Elettronici, Direttiva 2002/96/EC in vigore dal 13 Agosto 2005, prodotti appartenenti alla categoria dei Materiali Elettrici ed Elettronici non possono più essere eliminati come rifiuti municipali: i produttori di detti materiali saranno obbligati a ritirare ogni prodotto alla fine del suo ciclo di vita. MSI si adegnerà a tale Direttiva ritirando tutti i prodotti marchiati MSI che sono stati venduti all'interno dell'Unione Europea alla fine del loro ciclo di vita. È possibile portare i prodotti nel più vicino punto di raccolta

CONTENTS

Copyright Notice	ii
Trademarks	ii
Revision History.....	ii
Technical Support.....	ii
Safety Instructions.....	iii
FCC-B Radio Frequency Interference Statement.....	iv
WEEE (Waste Electrical and Electronic Equipment) Statement	v
Chapter 1 Getting Started.....	1-1
Mainboard Specifications	1-2
Mainboard Layout	1-4
Packing Checklist.....	1-5
Chapter 2 Hardware Setup.....	2-1
Quick Components Guide	2-2
CPU (Central Processing Unit)	2-3
Memory	2-7
Power Supply	2-11
Back Panel.....	2-12
Connectors.....	2-14
Switch.....	2-20
Buttons	2-21
Slots	2-22
LED Status Indicators	2-25
Chapter 3 BIOS Setup.....	3-1
Entering Setup	3-2
The Main Menu	3-4
Standard CMOS Features.....	3-6
Advanced BIOS Features	3-8
Integrated Peripherals.....	3-11
Power Management Setup.....	3-13
H/W Monitor	3-16
BIOS Setting Password.....	3-17
Green Power	3-18
Cell Menu	3-19
User Settings.....	3-26
M-Flash	3-27
Load Fail-Safe/ Optimized Defaults	3-30

Appendix A Realtek Audio	A-1
Installing the Realtek HD Audio Driver.....	A-2
Software Configuration.....	A-4
Hardware Setup.....	A-19
Appendix B Overclocking Center	B-1
Activating Overclocking Center.....	B-2
System Info.....	B-3
DOT.....	B-5
Appendix C Intel ICH10R SATA RAID	C-1
Introduction.....	C-2
BIOS Configuration.....	C-3
Installing Driver.....	C-10
Installing Software.....	C-12
RAID Migration Instructions.....	C-16
Recovery Volume Creation.....	C-23
Degraded RAID Array.....	C-27

Chapter 1

Getting Started

Thank you for choosing the **X58 Pro-E Series** (MS-7522 v3.X) ATX mainboard. The **X58 Pro-E Series** mainboards are based on **Intel® X58 & ICH10R** chipsets for optimal system efficiency. Designed to fit the advanced **Intel® i7 LGA1366** processor, the **X58 Pro-E Series** deliver a high performance and professional desktop platform solution.

MAINBOARD SPECIFICATIONS

Processor Support

- Intel® i7 processors in the LGA1366 package
(For the latest information about CPU, please visit <http://www.msi.com/index.php?func=cpuform2>)

Supported QPI

- Up to 6.4 GT/s

Chipset

- North Bridge: Intel® X58 chipset
- South Bridge: Intel® ICH10R chipset

Memory Support

- 6 DDR3 DIMMs support DDR3 1600(OC)/ 1333/ 1066/ 800 SDRAM speed(Memory size 24GB Max)
- Supports 1Gb/ 2Gb/ 4Gb DRAM size
- Supports x8/ x16 data lines per DIMM
- Supports up to 3 channels mode
(For more information on compatible components, please visit <http://www.msi.com/index.php?func=testreport>)

LAN

- Supports PCIE LAN 10/100/1000 Fast Ethernet by Realtek 8111C

Audio

- Chip integrated by Realtek® ALC889
- Flexible 8-channel audio with jack sensing
- Compliant with Azalia 1.0 Spec

IDE

- 1 IDE port by JMicron® JMB363
- Supports Ultra DMA 66/100/133 mode
- Supports PIO, Bus Master operation mode

SATA

- 6 SATA ports (SATA1~6) by ICH10R
- 1 SATA port (SATA7) by JMicron® JMB363
- 1 E-SATA port by JMicron® JMB363
- Supports storage and data transfers at up to 3 Gb/s

RAID

- SATA1~6 support Intel Matrix Storage Technology (AHCI + RAID 0/1/5/10) by ICH10R

1394

- 2 1394 ports (rear*1, front*1) by JMicron® JMB381

Connectors

- Back panel
 - 1 PS/2 mouse port
 - 1 PS/2 keyboard port

- 1 Optical S/PDIF-Out port
- 1 1394 port
- 1 eSATA port
- 6 USB 2.0 Ports
- 1 LAN jack
- 6 flexible audio jacks
- On-Board Connectors
 - 3 USB 2.0 connectors
 - 1 1394 connector
 - 1 chassis intrusion connector
 - 1 serial port connector
 - 1 TPM Module connector
 - 1 CD-In connector
 - 1 front audio connector
 - 1 Clear CMOS button
 - 1 Power button
 - 1 Reset button

TPM (optional)

- - Supports TPM

Slots

- 2 PCI Express gen2 x16 slots (PCI_E2, PCI_E4)
- 1 PCI Express x16 slot supports up to PCI Express gen2 x4 speed (PCI_E5)
- 2 PCI Express gen1 x1 slots
- 2 PCI slots, support 3.3V/ 5V PCI bus Interface

Form Factor

- ATX (30.5cm X 24.4cm)

Mounting

- 9 mounting holes

MAINBOARD LAYOUT

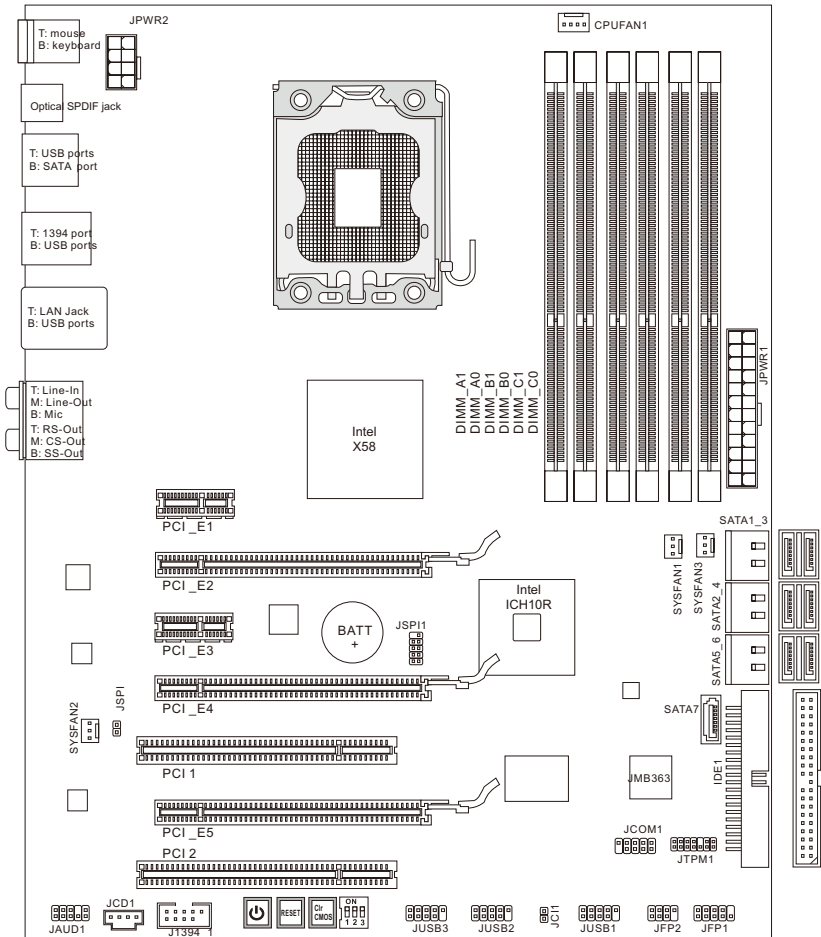

X58 Pro-E Series (MS-7522 v3.X) Mainboard

PACKING CHECKLIST



MSI mainboard



MSI Driver/Utility DVD



SATA Cable (Optional)



Power Cable



USB Bracket (Optional)

Standard Cable for
IDE Devices

Back IO Shield

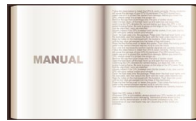

User's Guide

* The pictures are for reference only and may vary from the packing contents of the product you purchased.

Chapter 2

Hardware Setup

This chapter provides you with the information about hardware setup procedures. While doing the installation, be careful in holding the components and follow the installation procedures. For some components, if you install in the wrong orientation, the components will not work properly.

Use a grounded wrist strap before handling computer components. Static electricity may damage the components.

QUICK COMPONENTS GUIDE

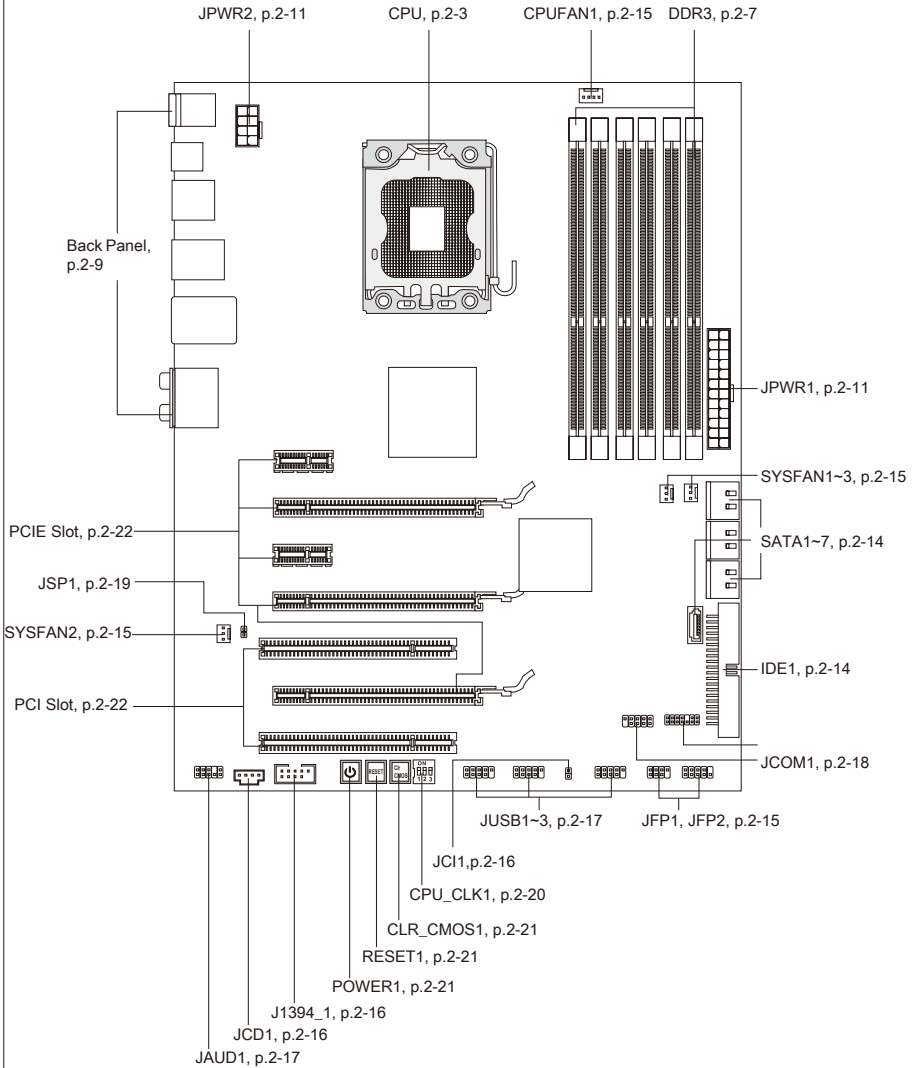

CPU (CENTRAL PROCESSING UNIT)

When you are installing the CPU, make sure to install the cooler to prevent overheating. If you do not have the CPU cooler, consult your dealer before turning on the computer. For the latest information about CPU, please visit <http://www.msi.com/index.php?func=cpuform2>

Important

Overheating

Overheating will seriously damage the CPU and system. Always make sure the cooling fan can work properly to protect the CPU from overheating. Make sure that you apply an even layer of thermal paste (or thermal tape) between the CPU and the heatsink to enhance heat dissipation.

Replacing the CPU

While replacing the CPU, always turn off the ATX power supply or unplug the power supply's power cord from the grounded outlet first to ensure the safety of CPU.

Overclocking

This mainboard is designed to support overclocking. However, please make sure your components are able to tolerate such abnormal setting, while doing overclocking. Any attempt to operate beyond product specifications is not recommended. We do not guarantee the damages or risks caused by inadequate operation or beyond product specifications.

Introduction to LGA 1366 CPU

The pin-pad side of LGA 1366 CPU.

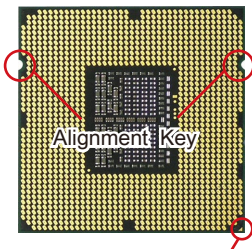

Yellow triangle is the Pin 1 indicator

The surface of LGA 1366 CPU. Remember to apply some thermal paste on it for better heat dispersion.

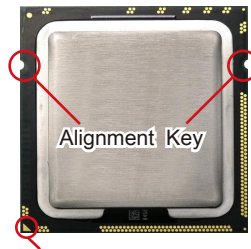

Yellow triangle is the Pin 1 indicator

CPU & Cooler Installation

When you are installing the CPU, make sure the CPU has a cooler attached on the top to prevent overheating. Meanwhile, do not forget to apply some thermal paste on CPU before installing the heat sink/cooler fan for better heat dispersion.

Follow the steps below to install the CPU & cooler correctly. Wrong installation will cause the damage of your CPU & mainboard.

1. Open the load level.
2. Lift the load lever up and open the load plate.

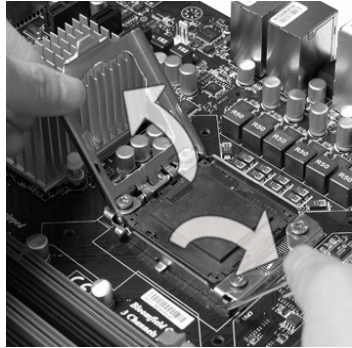
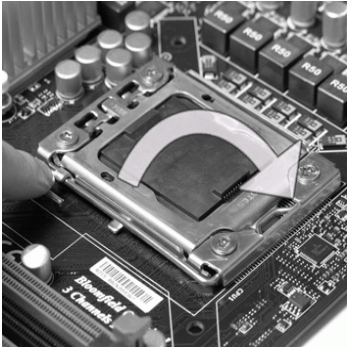

3. The CPU socket has a plastic cap on it to protect the contact from damage. Before you install CPU, always cover it to protect the socket pin. Remove the cap from the lever hinge side (as the arrow shows).
4. After confirming the CPU direction for correct mating, put down the CPU in the socket housing frame. Be sure to grasp on the edge of the CPU base. Note that the alignment keys are matched.

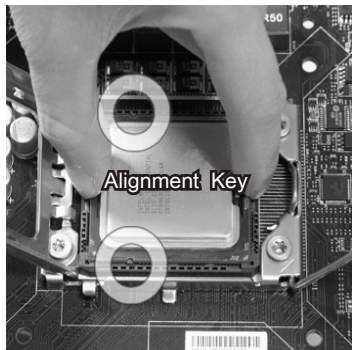
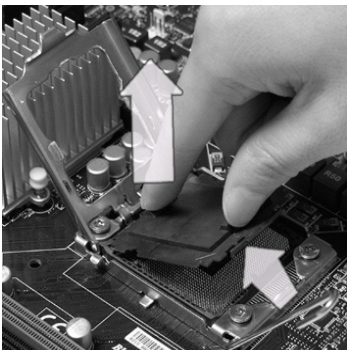

5. Visually inspect if the CPU is seated well into the socket. If not, take out the CPU with pure vertical motion and reinstall.

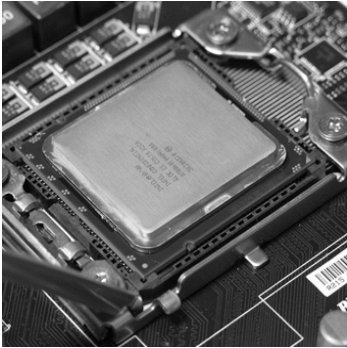

6. Cover the load plate onto the package.

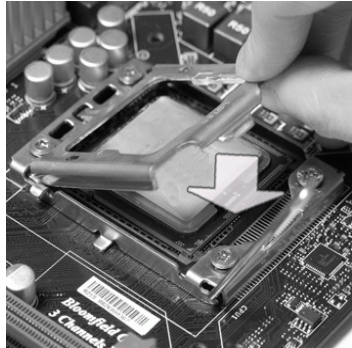

7. Press down the load lever lightly onto the load plate, and then secure the lever with the hook under retention tab.

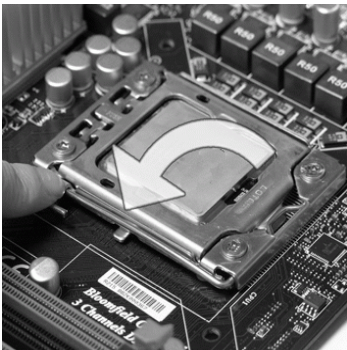

8. Make sure the four hooks are in proper position before you install the cooler.



Important

- Confirm if your CPU cooler is firmly installed before turning on your system.
- Do not touch the CPU socket pins to avoid damaging.

Hardware Setup

- Align the holes on the mainboard with the heatsink. Push down the cooler until its four clips get wedged into the holes of the mainboard.

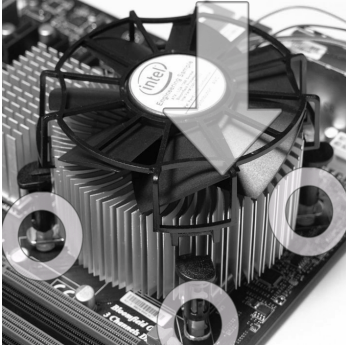

- Press the four hooks down to fasten the cooler.

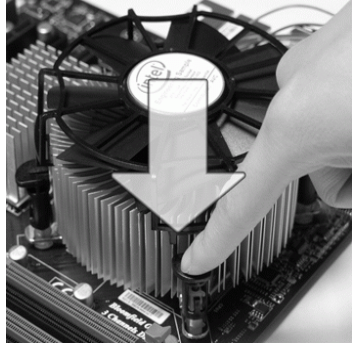

- Turn over the mainboard to confirm that the clip-ends are correctly inserted.

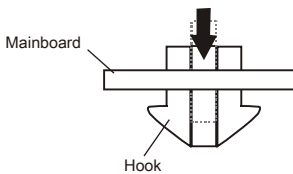

- Finally, attach the CPU Fan cable to the CPU fan connector on the mainboard.

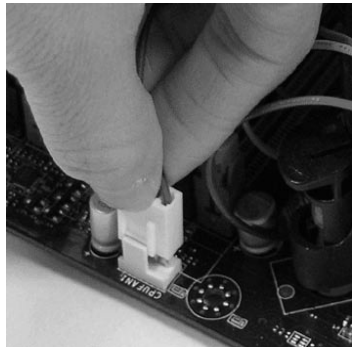

Important

- Read the CPU status in BIOS.
- Whenever CPU is not installed, always protect your CPU socket pin with the plastic cap covered to avoid damaging.
- Mainboard photos shown in this section are for demonstration of the CPU/ cooler installation only. The appearance of your mainboard may vary depending on the model you purchase.
- Please refer to the documentation in the CPU fan package for more details about the CPU fan installation.

MEMORY

These DIMM slots are used for installing memory modules.
For more information on compatible components, please visit
<http://www.msi.com/index.php?func=testreport>

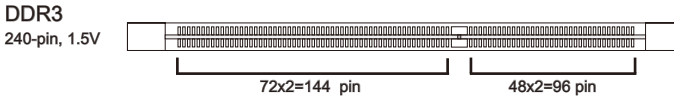

Memory Population Rules

Please refer to the following illustrations for memory population rules.

Single-Channel mode

When you have only one memory module, please always insert it into the DIMM_A0 first (as way 1 shown in below).



①

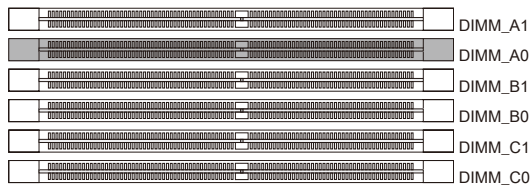

Dual-Channel mode

In Dual-Channel mode, the memory modules can transmit and receive data with two data bus lines simultaneously. Enabling Dual-Channel mode can enhance the system performance. When you have two memory modules, please always insert them into the DIMM_A0 & DIMM_B0 (as way 2 shown in below).

②

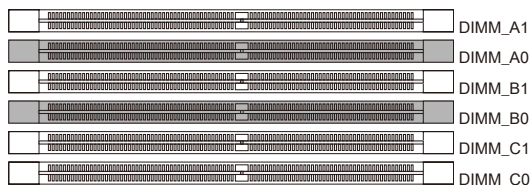

Triple-Channel mode

In Triple-Channel mode, the memory modules can transmit and receive data with three data bus lines simultaneously. Enabling Three-Channel mode can enhance the best system performance. When you have three or more memory modules, please always insert them as the way 3/ 4/ 5/ 6 (shown in below) to get the best system performance.

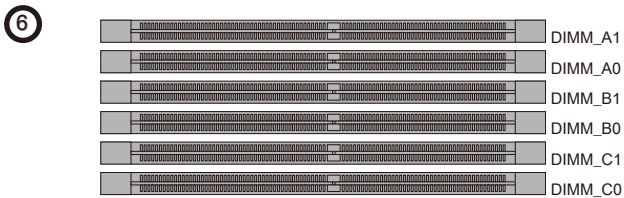
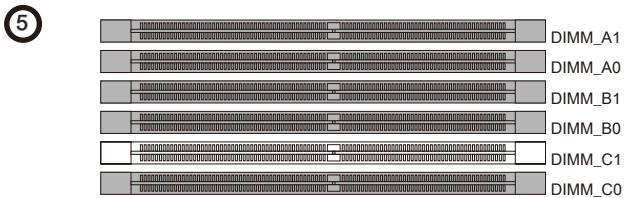
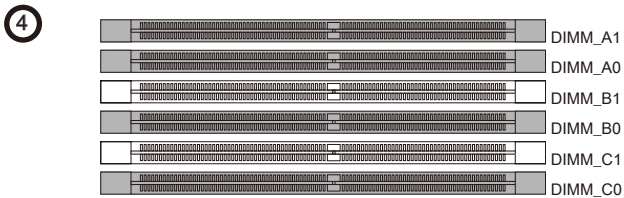
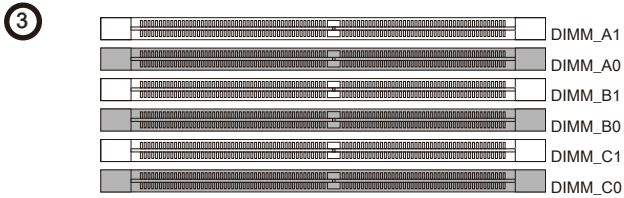

Important

- *DDR3 memory modules are not interchangeable with DDR2 and the DDR3 standard is not backwards compatible. You should always install DDR3 memory modules in the DDR3 DIMM slots.*
- *In Three/ Dual-Channel mode, make sure that you install memory modules of **the same type and density** in different channel DIMM slots.*
- *To enable successful system boot-up, always insert the memory modules into the **DIMM_A0** first.*
- *Due to the chipset resource deployment, the system density will only be detected up to 23+GB (not full 24GB) when each DIMM is installed with a 4GB memory module.*
- *When you install incorrect memory module (the SA2-pin of the memory module connects to Ground) in the DIMM_C0/C1, the LED beside DIMM_C0 will light red color to remind you. The position of the LED is shown as below. Double confirm with your memory module vender for the third channelsupports.*

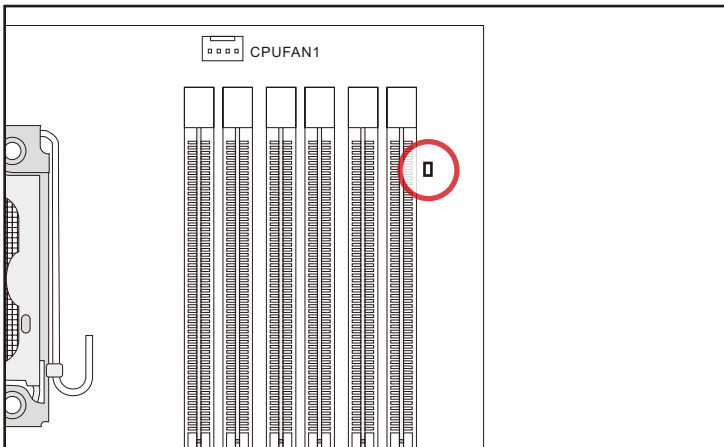

Installing Memory Modules

1. The memory module has only one notch on the center and will only fit in the right orientation.
2. Insert the memory module vertically into the DIMM slot. Then push it in until the golden finger on the memory module is deeply inserted in the DIMM slot. The plastic clip at each side of the DIMM slot will automatically close when the memory module is properly seated.
3. Manually check if the memory module has been locked in place by the DIMM slot clips at the sides.

Important

You can barely see the golden finger if the memory module is properly inserted in the DIMM slot.

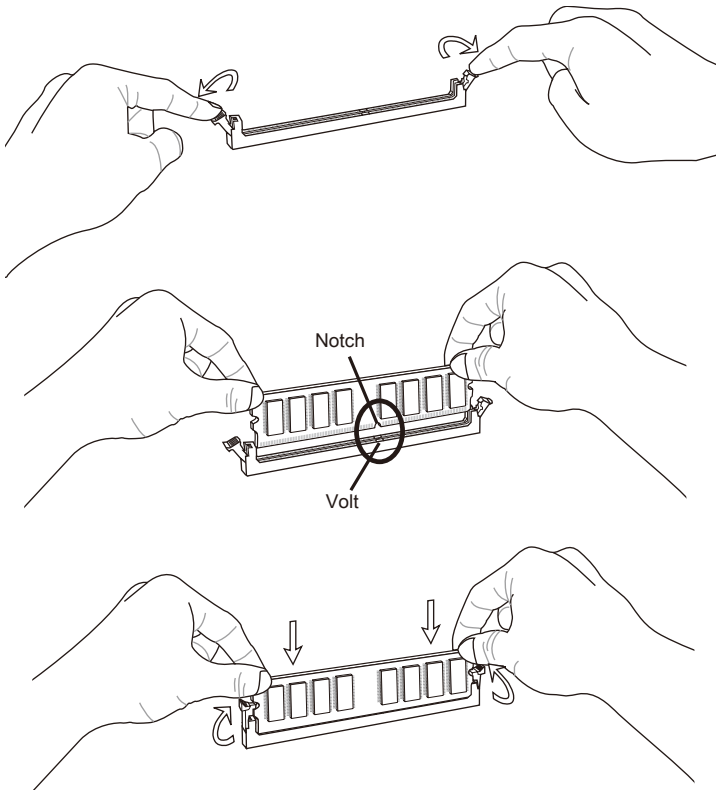

POWER SUPPLY

ATX 24-pin Power Connector: JPWR1

This connector allows you to connect an ATX 24-pin power supply. To connect the ATX 24-pin power supply, make sure the plug of the power supply is inserted in the proper orientation and the pins are aligned. Then push down the power supply firmly into the connector.

You may use the 20-pin ATX power supply as you like. If you'd like to use the 20-pin ATX power supply, please plug your power supply along with pin 1 & pin 13 (refer to the image at the right hand).

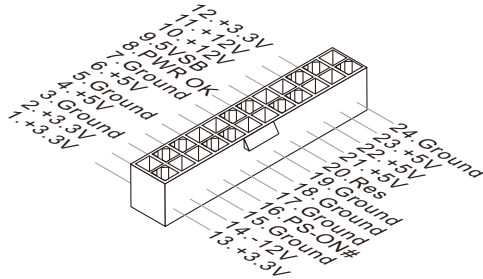

SSI 8-pin CPU Power Connector: JPWR2

This connector provides 12V power output to the CPUs.

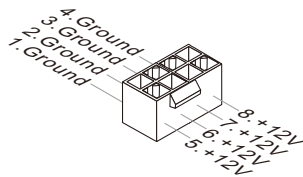

Important

- Make sure that all the connectors are connected to proper ATX power supplies to ensure stable operation of the mainboard.
- Power supply of 350 watts (and above) is highly recommended for system stability.

BACK PANEL

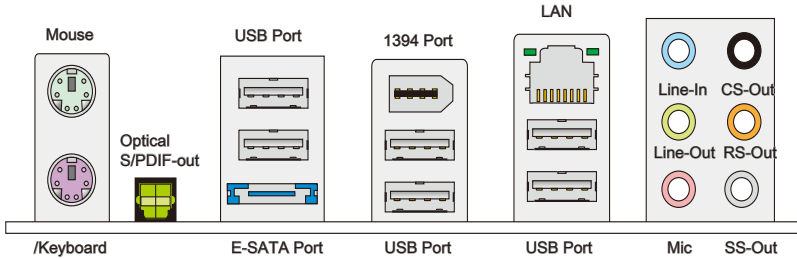

► Mouse/Keyboard

The standard PS/2[®] mouse/keyboard DIN connector is for a PS/2[®] mouse/keyboard.

► Optical S/PDIF-Out

This SPDIF (Sony & Philips Digital Interconnect Format) connector is provided for digital audio transmission to external speakers through an optical fiber cable.

► USB Port

The USB (Universal Serial Bus) port is for attaching USB devices such as keyboard, mouse, or other USB-compatible devices.

► E-SATA Port

The E-SATA (External-SATA) port is for attaching the E-SATA hard drive.

► 1394 Port (optional)

The IEEE 1394 port on the back panel provides connection to IEEE 1394 devices.

► LAN

The standard RJ-45 LAN jack is for connection to the Local Area Network (LAN). You can connect a network cable to it.

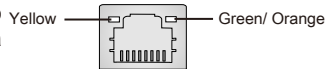

LED	Color	LED State	Condition
Left	Yellow	Off	LAN link is established.
		On (Steady state)	LAN link is established.
		On (brighter & pulsing)	The computer is communicating with another computer on the LAN.
Right	Green	Off	10 Mbits/sec data rate is selected.
		On	100 Mbits/sec data rate is selected.
	Orange	On	1000 Mbits/sec data rate is selected.

► Audio Ports

These audio connectors are used for audio devices. It is easy to differentiate between audio effects according to the color of audio jacks.

- Line-In (Blue) - Line In, is used for external CD player, tape-player or other audio devices.
- Line-Out (Green) - Line Out, is a connector for speakers or headphones.
- Mic (Pink) - Mic, is a connector for microphones.
- CS-Out (Orange) - Center/ Subwoofer Out in 5.1/ 7.1 channel mode.
- RS-Out (Black) - Rear-Surround Out in 4/ 5.1/ 7.1 channel mode.
- SS-Out (Gray) - Side-Surround Out 7.1 channel mode.

CONNECTORS

IDE Connector: IDE1

This connector supports IDE hard disk drives, optical disk drives and other IDE devices.

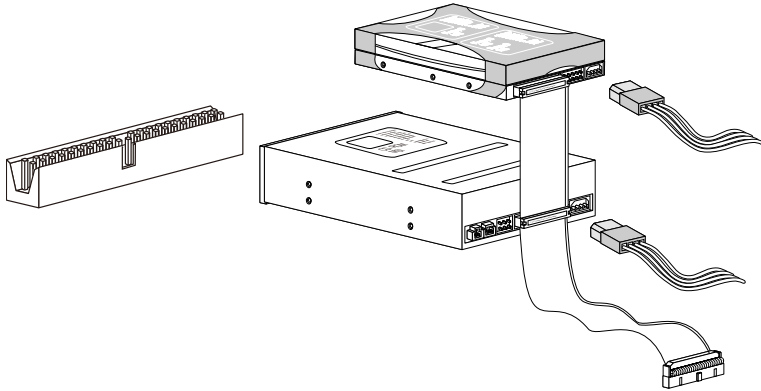

Important

If you install two IDE devices on the same cable, you must configure the drives separately to master / slave mode by setting jumpers. Refer to IDE device's documentation supplied by the vendors for jumper setting instructions.

Serial ATA Connector: SATA1~7

This connector is a high-speed Serial ATA interface port. Each connector can connect to one Serial ATA device.

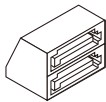

SATA1~6 stack SATA connectors are supported by ICH10R



SATA7 connector is supported by JMB363

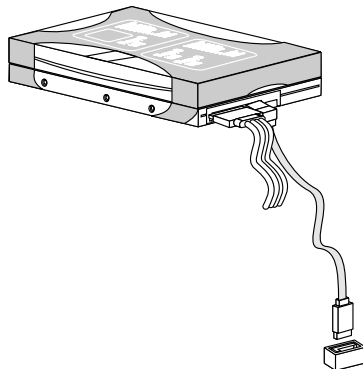

Important

- Please do not fold the Serial ATA cable into 90-degree angle. Otherwise, data loss may occur during transmission.
- Please always use the Intel default SATA connectors (SATA1~6) first.

Front Panel Connector: JFP1, JFP2

This connector is for electrical connection to the front panel switches and LEDs. The JFP1 is compliant with Intel® Front Panel I/O Connectivity Design Guide.

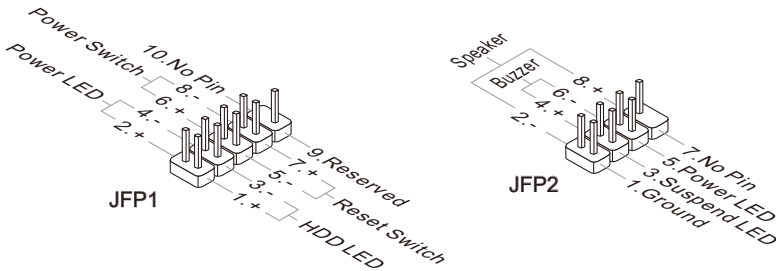
**Fan Power Connectors: CPUFAN1, SYSFAN1~3**

The fan power connectors support system cooling fan with +12V. When connecting the wire to the connectors, always note that the red wire is the positive and should be connected to the +12V; the black wire is Ground and should be connected to GND. If the mainboard has a System Hardware Monitor chipset on-board, you must use a specially designed fan with speed sensor to take advantage of the CPU fan control.

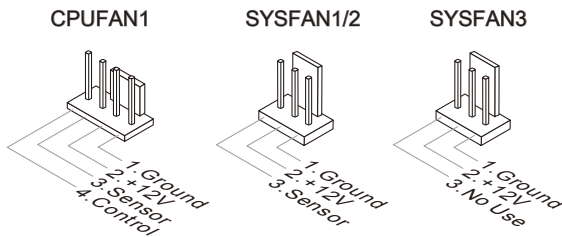
**Important**

- Please refer to the recommended CPU fans at processor's official website or consult the vendors for proper CPU cooling fan.
- CPUFAN1 supports fan control. You can install **Overclocking Center** utility that will automatically control the CPU fan speed according to the actual CPU temperature.
- Fan cooler set with 3 or 4 pins power connector are both available for CPUFAN1.
- SYSFAN1 and SYSFAN2 support fan control, too. You may select how percentage of speed for the SYSFAN1/2 in BIOS.

Chassis Intrusion Connector: JCI1

This connector connects to the chassis intrusion switch cable. If the chassis is opened, the chassis intrusion mechanism will be activated. The system will record this status and show a warning message on the screen. To clear the warning, you must enter the BIOS utility and clear the record.

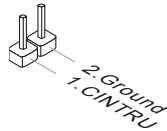

CD-In Connector: JCD1

This connector is provided for external audio input.

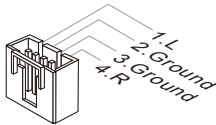

IEEE1394 Connector: J1394_1

This connector allows you to connect the IEEE1394 device via an optional IEEE1394 bracket.

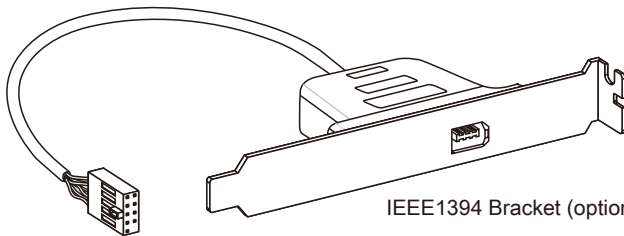
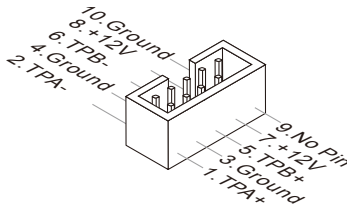

IEEE1394 Bracket (optional)

Front USB Connector: JUSB1 / JUSB2 / JUSB3

This connector, compliant with Intel® I/O Connectivity Design Guide, is ideal for connecting high-speed USB interface peripherals such as USB HDD, digital cameras, MP3 players, printers, modems and the like.

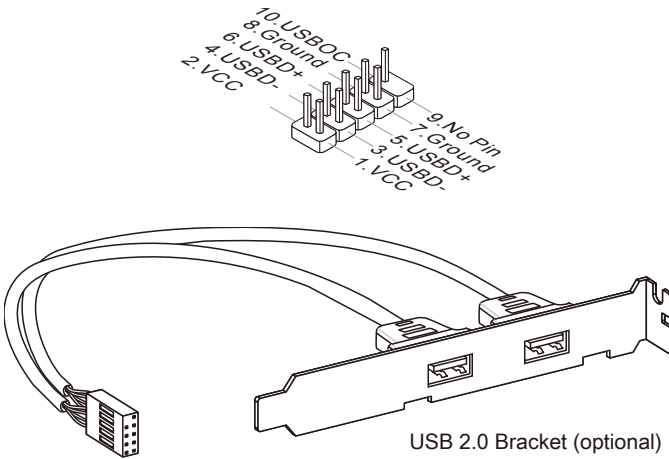

Important

Note that the pins of VCC and GND must be connected correctly to avoid possible damage.

Front Panel Audio Connector: JAUD1

This connector allows you to connect the front panel audio and is compliant with Intel® Front Panel I/O Connectivity Design Guide.

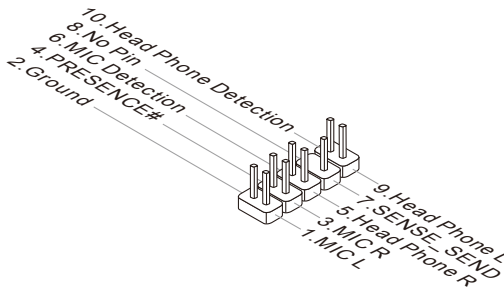

Serial Port Connector: JCOM1

This connector is a 16550A high speed communication port that sends/ receives 16 bytes FIFOs. You can attach a serial device.

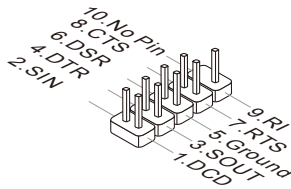

TPM Module connector: JTPM1

This connector connects to a TPM (Trusted Platform Module) module (optional). Please refer to the TPM security platform manual for more details and usages.

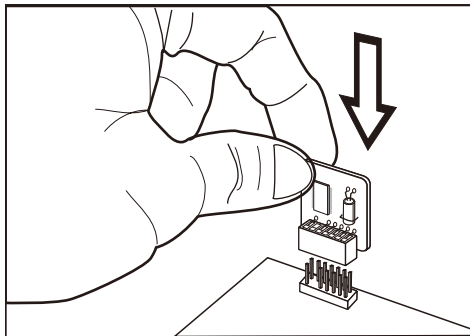
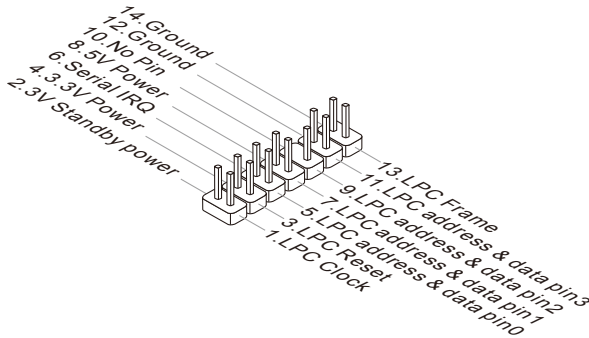

S/PDIF-Out Connector: JSP1 (for HDMI graphics card only)

This connector is used to connect S/PDIF (Sony & Philips Digital Interconnect Format) interface for digital audio transmission to the HDMI graphics card.

GND
SPDIF0

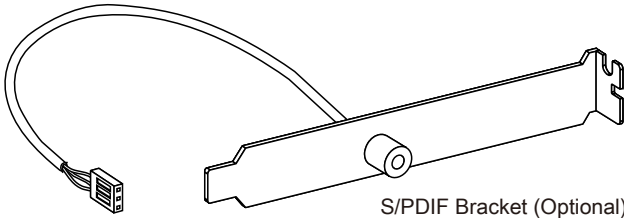

SWITCH

Hardware Overclock Base clock Switch: CPU_CLK1

You can overclock the Base clock to increase the processor frequency by changing this switch. Follow the instructions below to set the base clock.



133 MHz
(default)



166 MHz



200 MHz

important

- Make sure that you power off the system before changing the switch.
- HW overclocking may cause instability or crash during boot, then please re-set the switch to default.
- You can also overclock by setting BIOS. BIOS overclocking may also cause crash during boot and then please reboot the system 3 times to restore default BIOS settings. For more details, please refer to the BIOS chapter.

BUTTONS

The motherboard provides the following button for you to set the computer's function. This section will explain how to change your motherboard's function through the use of button.

Clear CMOS Button: CLR_CMOS1

There is a CMOS RAM on board that has a power supply from external battery to keep the system configuration data. With the CMOS RAM, the system can automatically boot OS every time it is turned on. If you want to clear the system configuration, use the button to clear data. Press the button to clear the data.

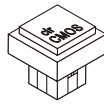

Important

Make sure that you power off the system before clearing CMOS data.

Power Button: POWER1

This power button is used to turn-on or turn-off the system. Press the button to turn-on or turn-off the system. This button will light after you power-on the system, and the light will turn-off when you power-off the system.



Reset Button: RESET1

This reset button is used to reset the system. Press the button to reset the system. This button will light when the system is in S0 status.

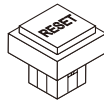

SLOTS

PCI (Peripheral Component Interconnect) Express Slot

The PCI Express slot supports the PCI Express interface expansion card.

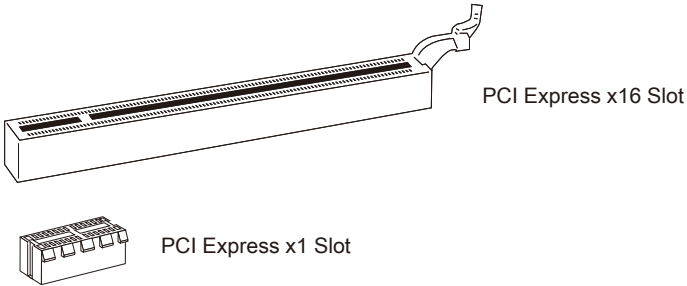

ATI CrossFireX™ (Multi-GPU) Technology

ATI CrossFireX™ is the ultimate multi-GPU performance gaming platform. Enabling game-dominating power, ATI CrossFireX™ technology enables two or more discrete graphics processors to work together to improve system performance. ATI CrossFireX™ technology allows you to expand your system's graphics capabilities. It allows you the ability to scale your system's graphics horsepower as you need it, supporting two or more ATI Radeon™ HD graphics cards, making this the most scalable gaming platform ever. The motherboard can auto detect the CrossFireX™ mode by software, therefore you don't have to enable the CrossFireX™ in BIOS by yourself. The following details the 2-way CrossFireX™ installation.

1. Install one ATI Radeon™ HD graphics card in the first PCIE x16 (PCI_E1) slot , then install one ATI Radeon™ HD graphics card in the third PCIE x16 (PCI_E4) slot.
2. With two cards installed, an CrossFireXTM Video Link cable is required to connect the golden fingers on the top of these two graphics cards (refer to the picture below). Please note that although you have installed two or more graphics cards, only the video outputs on the graphics card installed in PCI_E1 will work. Hence, you only need to connect a monitor to this graphics card.

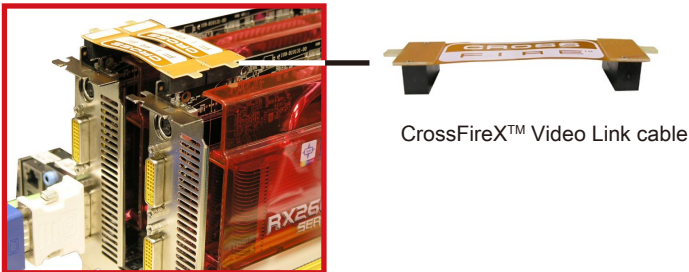

Important

- Motherboard photos shown in this section are for demonstration only. The appearance of your motherboard may vary depending on the model you purchase.
 - If you intend to install TWO graphics cards for CrossFireX™ mode, make sure that:
 - a. these two graphics cards are of the same brand and specifications;
 - b. these two cards are installed on both mazarine PCIE x16 slots.
 - Make sure that you connect an adequate power supply to the power connector on the graphics card to ensure stable operation of the graphics card.
 - Only Windows®XP with Service Pack 2 (SP2)& Windows®XP Professional x64 Edition & Windows®Vista support the CrossFireX™ function.
3. When all of the hardware and software has been properly set up and installed, reboot the system. After entering the O.S., click the “Catalyst™ Control Center” icon on the desktop. There is a setting in the Catalyst™ Control Center that needs to be enabled for CrossFireX™ to operate. The following aspect appears in Catalyst™ Control Center:

Select the Advanced View from the view drop menu.



Important

A CrossFireX™ system has four possible display modes:

- SuperTiling
- Scissor Mode
- Alternate Frame Rendering
- Super Anti-aliasing.

for more details, please consult the graphics card manual from the manufacturer.

PCI (Peripheral Component Interconnect) Slot

The PCI slot supports LAN card, SCSI card, USB card, and other add-on cards that comply with PCI specifications.

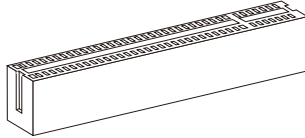

32-bit PCI Slot

Important

When adding or removing expansion cards, make sure that you unplug the power supply first. Meanwhile, read the documentation for the expansion card to configure any necessary hardware or software settings for the expansion card, such as jumpers, switches or BIOS configuration.

PCI Interrupt Request Routing

The IRQ, acronym of interrupt request line and pronounced I-R-Q, are hardware lines over which devices can send interrupt signals to the microprocessor. The PCI IRQ pins are typically connected to the PCI bus pins as follows:

	Order1	Order2	Order3	Order4
PCI Slot1	INT E#	INT F#	INT G#	INT H#
PCI Slot2	INT F#	INT G#	INT H#	INT E#

LED STATUS INDICATORS

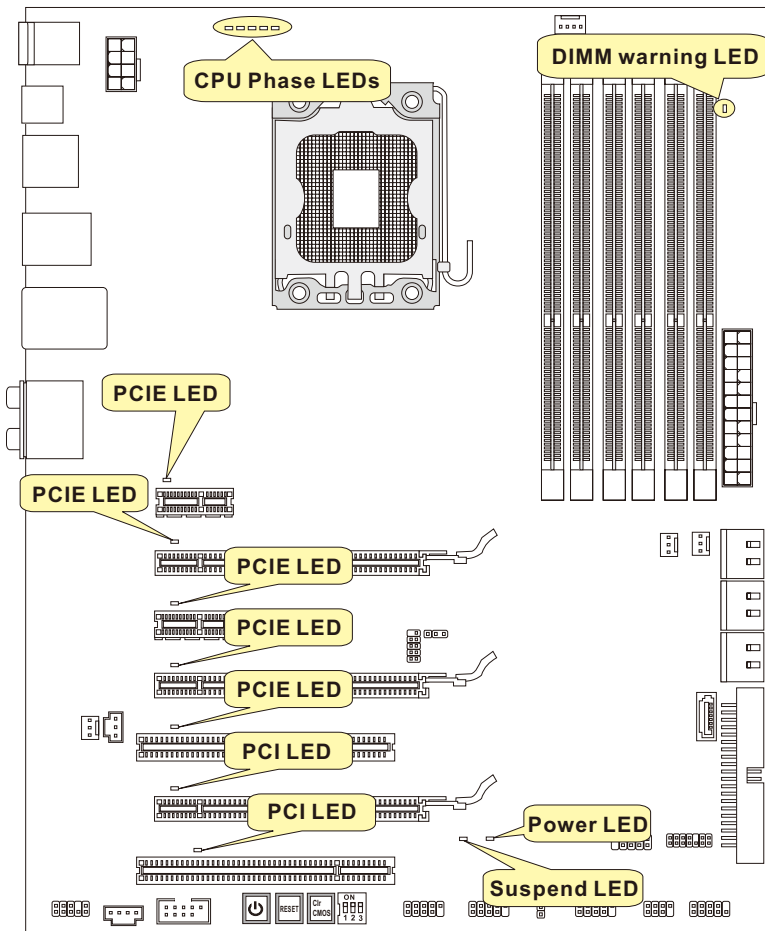

CPU Phase LEDs

These LEDs indicate the current CPU power phase mode. Follow the instructions below to read.

- 5 of the LEDs will light blue when CPU is in 5 phase power mode.
- 4 of the LEDs will light blue when CPU is in 4 phase power mode.
- 3 of the LEDs will light blue when CPU is in 3 phase power mode.
- 2 of the LEDs will light blue when CPU is in 2 phase power mode.
- 1 of the LEDs will light blue when CPU is in 1 phase power mode.

DIMM Warning LED

Lights red when the incorrect memory installed into DIMM_C0/ DIMM_C1 (the DIMMs of 3rd channel).

Power LED

Lights green when the system is in power-on(S0/S1) status.

Suspend LED

Lights yellow when the system is suspended (S3/S4/S5).

PCIE and PCI LEDs

Lights blue when the slots is functional.

Chapter 3

BIOS Setup

This chapter provides information on the BIOS Setup program and allows you to configure the system for optimum use.

You may need to run the Setup program when:

- An error message appears on the screen during the system booting up, and requests you to run SETUP.
- You want to change the default settings for customized features.

ENTERING SETUP

Power on the computer and the system will start POST (Power On Self Test) process. When the message below appears on the screen, press key to enter Setup.

Press DEL to enter SETUP

If the message disappears before you respond and you still wish to enter Setup, restart the system by turning it OFF and On or pressing the RESET button. You may also restart the system by simultaneously pressing <Ctrl>, <Alt>, and <Delete> keys.

Important

- *The items under each BIOS category described in this chapter are under continuous update for better system performance. Therefore, the description may be slightly different from the latest BIOS and should be held for reference only.*
- *Upon boot-up, the 1st line appearing after the memory count is the BIOS version. It is usually in the format:*

A7522IMS V3.1 032509 where:

1st digit refers to BIOS maker as A = AMI, W = AWARD, and P = PHOENIX.

2nd - 5th digit refers to the model number.

6th digit refers to the chipset as I = Intel, N = nVidia, A = AMD and V = VIA.

7th - 8th digit refers to the customer as MS = all standard customers.

V3.1 refers to the BIOS version.

032509 refers to the date this BIOS was released.

Control Keys

<↑>	Move to the previous item
<↓>	Move to the next item
<←>	Move to the item in the left hand
<→>	Move to the item in the right hand
<Enter>	Select the item
<Esc>	Jumps to the Exit menu or returns to the main menu from a submenu
<+ /PU>	Increase the numeric value or make changes
<- /PD>	Decrease the numeric value or make changes
<F1>	General Help
<F4>	Enter CPU Specifications submenu
<F5>	Enter Memory-Z submenu
<F6>	Load Optimized Defaults
<F8>	Load Fail-Safe Defaults
<F10>	Save all the CMOS changes and exit

Getting Help

After entering the Setup menu, the first menu you will see is the Main Menu.

Main Menu

The main menu lists the setup functions you can make changes to. You can use the arrow keys (↑ ↓) to select the item. The on-line description of the highlighted setup function is displayed at the bottom of the screen.

Sub-Menu

If you find a right pointer symbol (as shown in the right view) appears to the left of certain fields that means a sub-menu can be launched from this field. A sub-menu contains additional options for a field parameter. You can use arrow keys (↑ ↓) to highlight the field and press <Enter> to call up the sub-menu. Then you can use the control keys to enter values and move from field to field within a sub-menu. If you want to return to the main menu, just press the <Esc >.

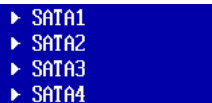

▶ SATA1
▶ SATA2
▶ SATA3
▶ SATA4

General Help <F1>

The BIOS setup program provides a General Help screen. You can call up this screen from any menu by simply pressing <F1>. The Help screen lists the appropriate keys to use and the possible selections for the highlighted item. Press <Esc> to exit the Help screen.

THE MAIN MENU

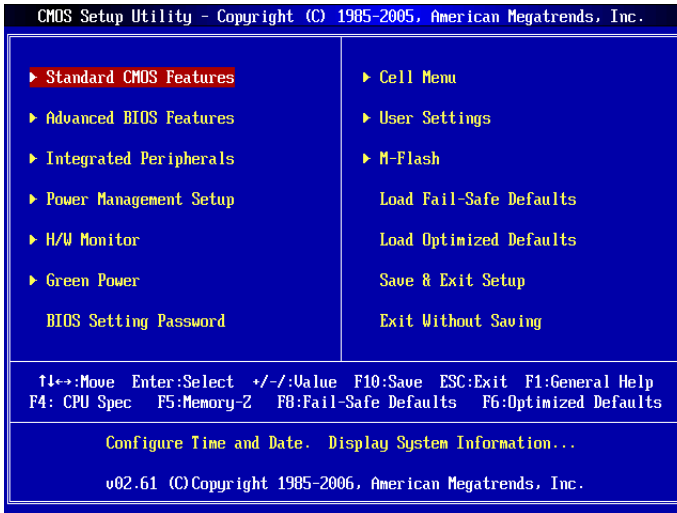

▶ **Standard CMOS Features**

Use this menu for basic system configurations, such as time, date etc.

▶ **Advanced BIOS Features**

Use this menu to setup the items of AMI's special enhanced features.

▶ **Integrated Peripherals**

Use this menu to specify your settings for integrated peripherals.

▶ **Power Management Setup**

Use this menu to specify your settings for power management.

▶ **H/W Monitor**

This entry shows your PC health status.

▶ **Green Power**

Use this menu to specify the power phase.

▶ **BIOS Setting Password**

Use this menu to set the password for BIOS.

▶ **Cell Menu**

Use this menu to specify your settings for frequency/voltage control and overclocking.

► User Settings

Use this menu to save/ load your settings to/ from CMOS for BIOS.

► M-Flash

Use this menu to read/ flash the BIOS from storage drive (FAT/ FAT32 format only).

► Load Fail-Safe Defaults

Use this menu to load the default values set by the BIOS vendor for stable system performance.

► Load Optimized Defaults

Use this menu to load the default values set by the mainboard manufacturer specifically for optimal performance of the mainboard.

► Save & Exit Setup

Save changes to CMOS and exit setup.

► Exit Without Saving

Abandon all changes and exit setup.

STANDARD CMOS FEATURES

The items in Standard CMOS Features Menu includes some basic setup items. Use the arrow keys to highlight the item and then use the <PgUp> or <PgDn> keys to select the value you want in each item.

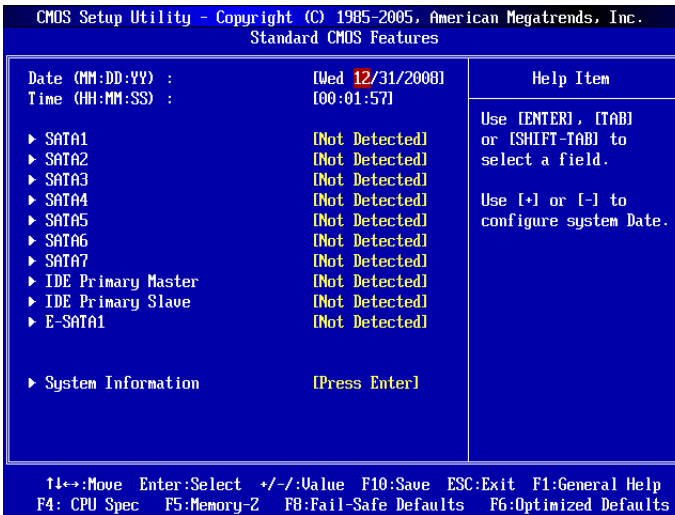

▶ Date (MM:DD:YY)

This allows you to set the system to the date that you want (usually the current date). The format is <day><month> <date> <year>.

day	Day of the week, from Sun to Sat, determined by BIOS. Read-only.
month	The month from Jan. through Dec.
date	The date from 1 to 31 can be keyed by numeric function keys.
year	The year can be adjusted by users.

▶ Time (HH:MM:SS)

This allows you to set the system time that you want (usually the current time). The time format is <hour> <minute> <second>.

▶ SATA1~7 & IDE Primary Master/ Slave & E-SATA1

Press <Enter> to enter the sub-menu, and the following screen appears.

CMOS Setup Utility - Copyright (C) 1985-2005, American Megatrends, Inc.	
SATA1	
SATA1	Help Item
Device :Hard Disk	
Vendor :MAXTOR STM3320020AS	
Size :320.0GB	

► **Device / Vendor / Size**

It will showing the device information that you connected to the SATA connector.

► **LBA/Large Mode**

This allows you to enable or disable the LBA Mode. Setting to Auto enables LBA mode if the device supports it and the devices is not already formatted with LBA mode disabled.

► **DMA Mode**

Select DMA Mode.

► **Hard Disk S.M.A.R.T.**

This allows you to activate the S.M.A.R.T. (Self-Monitoring Analysis & Reporting Technology) capability for the hard disks. S.M.A.R.T is a utility that monitors your disk status to predict hard disk failure. This gives you an opportunity to move data from a hard disk that is going to fail to a safe place before the hard disk becomes offline.

Important

SATA1~7, IDE Primary Master/ Slave & E-SATA1 are appearing when you connect the HD devices to the IDE/ SATA connectors on the mainboard.

► **System Information**

Press <Enter> to enter the sub-menu, and the following screen appears.

This sub-menu shows the CPU information, BIOS version and memory status of your system (read only).

CMOS Setup Utility - Copyright (C) 1985-2005, American Megatrends, Inc.	
System Information	
	Help Item
Intel (R) Core(TM)2 Duo CPU E8300 @ 2.83GHz	
CPUID/MicroCode 10676/60C	
CPU Frequency 2.836GHz (333x8.5)	
BIOS Version 04.005 11172008	
Physical Memory 512MB	
Cache Size 6144 KB	

ADVANCED BIOS FEATURES

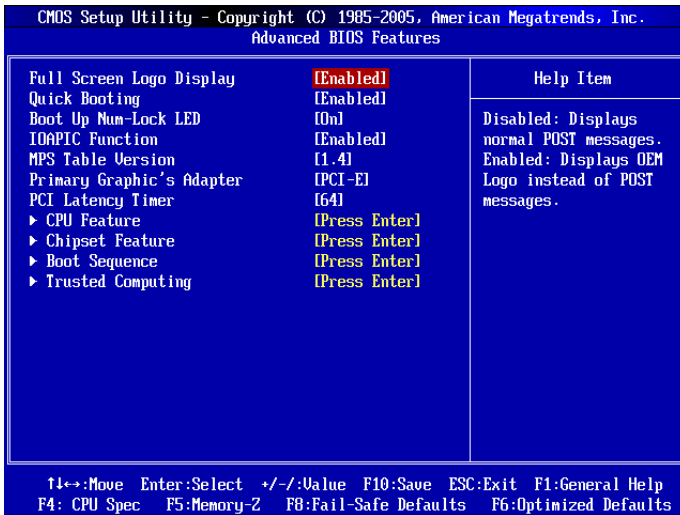

▶ Full Screen Logo Display

This item enables this system to show the company logo on the boot-up screen. Settings are:

- [Enabled] Shows a still image (logo) on the full screen at boot.
- [Disabled] Shows the POST messages at boot.

▶ Quick Booting

Setting the item to [Enabled] allows the system to boot within 10 seconds since it will skip some check items.

▶ Boot Up Num-Lock LED

This setting is to set the Num Lock status when the system is powered on. Setting to [On] will turn on the Num Lock key when the system is powered on. Setting to [Off] will allow users to use the arrow keys on the numeric keypad.

▶ IOAPIC Function

This field is used to enable or disable the APIC (Advanced Programmable Interrupt Controller). Due to compliance with PC2001 design guide, the system is able to run in APIC mode. Enabling APIC mode will expand available IRQ resources for the system.

▶ MPS Table Version

This field allows you to select which MPS (Multi-Processor Specification) version to be used for the operating system. You need to select the MPS version supported by your operating system. To find out which version to use, consult the vendor of your operating system.

► Primary Graphic's Adapter

This setting specifies which graphic card is your primary graphics adapter.

► PCI Latency Timer

This item controls how long each PCI device can hold the bus before another takes over. When set to higher values, every PCI device can conduct transactions for a longer time and thus improve the effective PCI bandwidth. For better PCI performance, you should set the item to higher values.

► CPU Feature

Press <Enter> to enter the sub-menu and the following screen appears:

CMOS Setup Utility - Copyright (C) 1985-2005, American Megatrends, Inc.		
CPU Feature		
Hyper-Threading Function	[Enabled]	Help Item
Execute Bit Support	[Disabled]	When 'Disabled' only one thread per enabled
Set Limit CPUID MaxVal to 3	[Disabled]	
Overspeed Protection	[Enabled]	

► Hyper-Threading Technology

The processor uses Hyper-Threading technology to increase transaction rates and reduces end-user response times. The technology treats the two cores inside the processor as two logical processors that can execute instructions simultaneously. In this way, the system performance is highly improved. If you disable the function, the processor will use only one core to execute the instructions. Please disable this item if your operating system doesn't support HT Function, or unreliability and instability may occur.

Important

Enabling the functionality of Hyper-Threading Technology for your computer system requires ALL of the following platform Components:

- CPU: An Intel® Pentium® 4 Processor with HT Technology;
- Chipset: An Intel® Chipset that supports HT Technology;
- BIOS: A BIOS that supports HT Technology and has it enabled;
- OS: An operating system that supports HT Technology.

For more information on Hyper-threading Technology, go to:

www.intel.com/info/hyperthreading

► Execute Bit Support

Intel's Execute Disable Bit functionality can prevent certain classes of malicious "buffer overflow" attacks when combined with a supporting operating system. This functionality allows the processor to classify areas in memory by where application code can execute and where it cannot. When a malicious worm attempts to insert code in the buffer, the processor disables code execution, preventing damage or worm propagation.

► Set Limit CPUID MaxVal to 3

The Max CPUID Value Limit is designed limit the listed speed of the processor to older operating systems.

► Overspeed Protection

Overspeed Protection function can monitor the current CPU draws as well as its power consumption. If it exceeds a certain level, the processor automatically reduces its clock speed. If you want to overclock your CPU, set it to [Disabled].

► Chipset Feature

Press <Enter> to enter the sub-menu and the following screen appears:

CMOS Setup Utility - Copyright (C) 1985-2005, American Megatrends, Inc.		
Chipset Feature		
HPET	[Disabled]	Help Item

► HPET

The HPET (High Precision Event Timers) is a component that is part of the chipset. You can enable it, and it will provide you with the means to get to it via the various ACPI methods.

► Boot Sequence

Press <Enter> to enter the sub-menu and the following screen appears:

CMOS Setup Utility - Copyright (C) 1985-2005, American Megatrends, Inc.		
Boot Sequence		
1st Boot Device	[USB:USB2.0 Car]	Help Item
2nd Boot Device	[SATA:SM-ST3320]	
3rd Boot Device	[CD/DVD:4M-ATAPI]	Specifies the boot sequence from the available devices
Boot From Other Device	[Yes]	

► 1st/ 2nd/ 3rd Boot Device

The item allows you to set the first/ second/ third boot device where BIOS attempts to load the disk operating system.

► Boot From Other Device

Setting the option to [Yes] allows the system to try to boot from other device, if the system fails to boot from 1st boot device.

► Trusted Computing

Press <Enter> to enter the sub-menu and the following screen appears:

CMOS Setup Utility - Copyright (C) 1985-2005, American Megatrends, Inc.		
Trusted Computing		
TCG/TPM Support	[No]	Help Item

► TCG/TPM SUPPORT

Setting the option to [Yes] enables TPM (Trusted Platform Module) to the system.

INTEGRATED PERIPHERALS

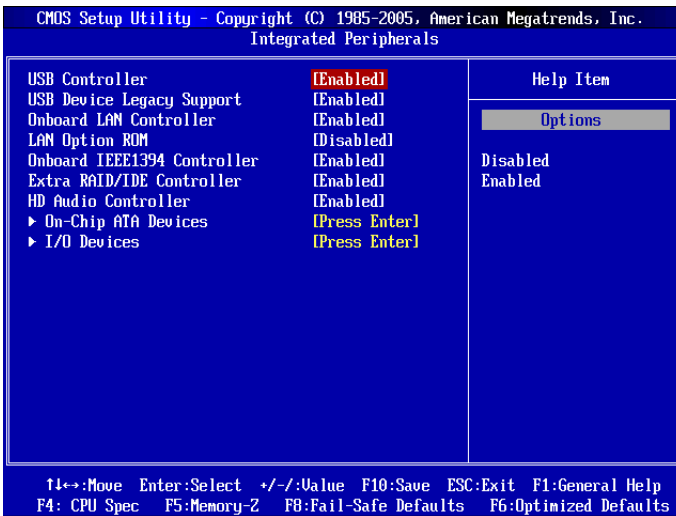

▶ USB Controller

This setting allows you to enable/disable the onboard USB controller.

▶ USB Device Legacy Support

Select [Enabled] if you need to use a USB-interfaced device in the operating system.

▶ Onboard LAN Controller

This item is used to enable/disable the onboard 1st LAN controller.

▶ LAN Option ROM

This item is used to decide whether to invoke the Boot ROM of the LAN controller.

▶ Onboard IEEE1394 Controller

This item allows you to enable/disable the onboard IEEE1394 controller.

▶ Extra RAID/ IDE Controller (JMB363 controller for SATA7 & E-SATA)

This item allows you to enable/disable the extra RAID/ IDE controller.

▶ HD Audio Controller

This setting is used to enable/disable the onboard audio controller.

▶ On-Chip ATA Devices (for ICH10R)

Press <Enter> to enter the sub-menu and the following screen appears:



BIOS Setup

▶ PCI IDE BusMaster

This item allows you to enable/ disable BIOS to used PCI busmastering for reading/ writing to IDE drives.

▶ On-Chip SATA Controller

These items allow users to enable or disable the SATA controller.

▶ RAID Mode

This item allows you to configure RAID mode for onboard SATA devices.

▶ I/O Devices

Press <Enter> to enter the sub-menu and the following screen appears:



▶ COM Port 1

Select an address and corresponding interrupt for the first serial port.

POWER MANAGEMENT SETUP

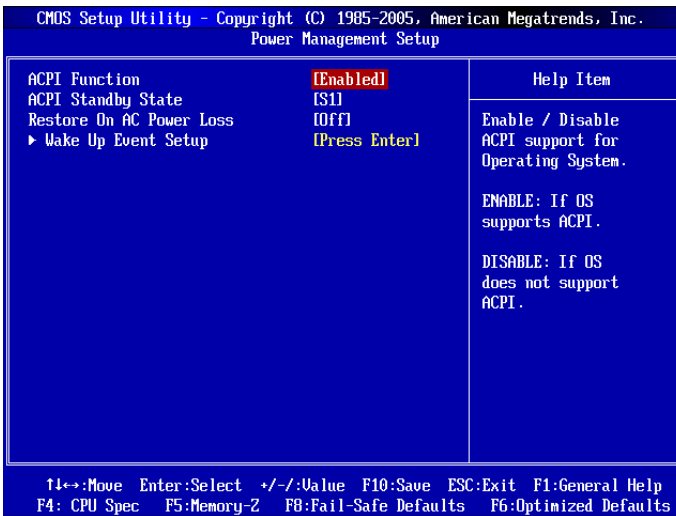

Important

S3-related functions described in this section are available only when your BIOS supports S3 sleep mode.

▶ ACPI Function

This item is to activate the ACPI (Advanced Configuration and Power Management Interface) Function. If your operating system is ACPI-aware, such as Windows 2000/XP, select [Enabled].

▶ ACPI Standby State

This item specifies the power saving modes for ACPI function. If your operating system supports ACPI, such as Windows 2000/XP, you can choose to enter the Standby mode in S1(POS) or S3(STR) fashion through the setting of this field. Settings are:

- [S1] The S1 sleep mode is a low power state. In this state, no system context is lost (CPU or chipset) and hardware maintains all system context.
- [S3] The S3 sleep mode is a lower power state where the information of system configuration and open applications/files is saved to main memory that remains powered while most other hardware components turn off to save energy. The information stored in memory will be used to restore the system when a "wake up" event occurs.

▶ Restore On AC Power Loss

This item specifies whether your system will reboot after a power failure or interrupt occurs. Settings are:

- [Off] Always leaves the computer in the power off state.

BIOS Setup

- [On] Always leaves the computer in the power on state.
- [Last State] Restores the system to the status before power failure or interrupt occurred.

► Wake Up Event Setup

Press <Enter> and the following sub-menu appears.

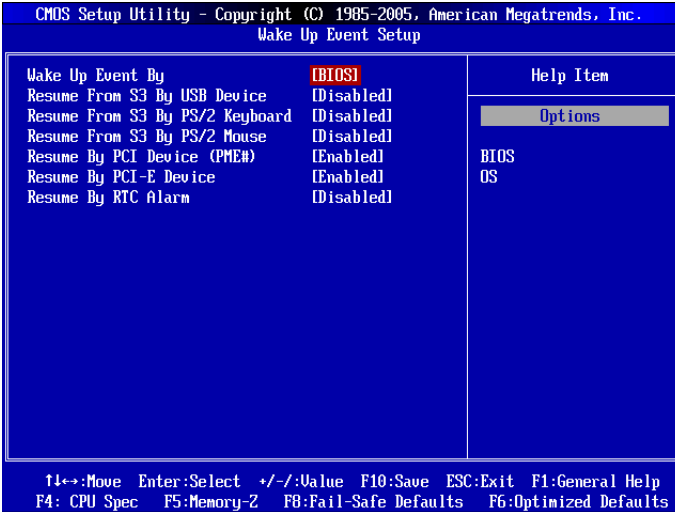

► Wake Up Event By

Setting to [BIOS] activates the following fields, and use the following fields to set the wake up events. Setting to [OS], the wake up events will be defined by OS.

► Resume From S3 By USB Device

The item allows the activity of the USB device to wake up the system from S3 (Suspend to RAM) sleep state.

► Resume From S3 By PS/2 Keyboard

This setting determines whether the system will be awakened from what power saving modes when input signal of the PS/2 keyboard is detected.

► Resume From S3 By PS/2 Mouse

This setting determines whether the system will be awakened from what power saving modes when input signal of the PS/2 mouse is detected.

► Resume By PCI Device (PME#)

When set to [Enabled], the feature allows your system to be awakened from the power saving modes through any event on PME (Power Management Event).

► Resume By PCI-E Device

When set to [Enabled], the feature allows your system to be awakened from the power saving modes through any event on PCIE device.

▶ Resume By RTC Alarm

The field is used to enable or disable the feature of booting up the system on a scheduled time/date.

▶ Date / HH:MM:SS

These two fields can specify the date/ time for power-on by alarm.

H/W MONITOR

CMOS Setup Utility - Copyright (C) 1985-2005, American Megatrends, Inc.		
H/W Monitor		
Chassis Intrusion	Disabled	Help Item
CPU Smart Fan Target	Disabled	Chassis Intrusion function
SYS FAN 1 Control	[100%]	
SYS FAN 2 Control	[100%]	
----- PC Health Status -----		
CPU Temperature	52°C/125°F	
IOH Temperature	59°C/138°F	
System Temperature	28°C/82°F	
CPU FAN Speed	2463 RPM	
SYS FAN 1 Speed	0 RPM	
SYS FAN 2 Speed	0 RPM	
CPU Vcore	1.208 V	
3.3V	3.104 V	
5V	4.834 V	
12V	12.056 V	
↑←→:Move Enter:Select +/-:Value F10:Save ESC:Exit F1:General Help F4: CPU Spec F5:Memory-Z F8:Fail-Safe Defaults F6:Optimized Defaults		

► Chassis Intrusion

The field enables or disables the feature of recording the chassis intrusion status and issuing a warning message if the chassis is once opened. To clear the warning message, set the field to [Reset]. The setting of the field will automatically return to [Enabled] later.

► CPU Smart Fan Target

The mainboard provides the Smart Fan function which can control the CPU fan speed automatically depending on the current temperature to keep it within a specific range. You can enable a fan target value here. If the current CPU fan temperature reaches to the target value, the smart fan function will be activated. It provides several sections to speed up for cooling down automatically.

► SYS FAN1/2 Control

This item allows users to select how percentage of speed for the SYS FAN1/2.

► PC Health Status

- CPU/ IOH/ System Temperature, CPU FAN/ SYS FAN1/ SYS FAN2 Speed, CPU Vcore, 3.3V, 5V, 12V

These items display the current status of all of the monitored hardware devices/components such as CPU voltage, temperatures and all fans' speeds.

BIOS SETTING PASSWORD

When you select this function, a message as below will appear on the screen:

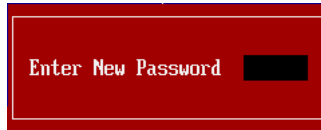

Type the password, up to six characters in length, and press <Enter>. The password typed now will replace any previously set password from CMOS memory. You will be prompted to confirm the password. Retype the password and press <Enter>. You may also press <Esc> to abort the selection and not enter a password.

To clear a set password, just press <Enter> when you are prompted to enter the password. A message will show up confirming the password will be disabled. Once the password is disabled, the system will boot and you can enter Setup without entering any password.

When a password has been set, you will be prompted to enter it every time you try to enter Setup. This prevents an unauthorized person from changing any part of your system configuration.

GREEN POWER

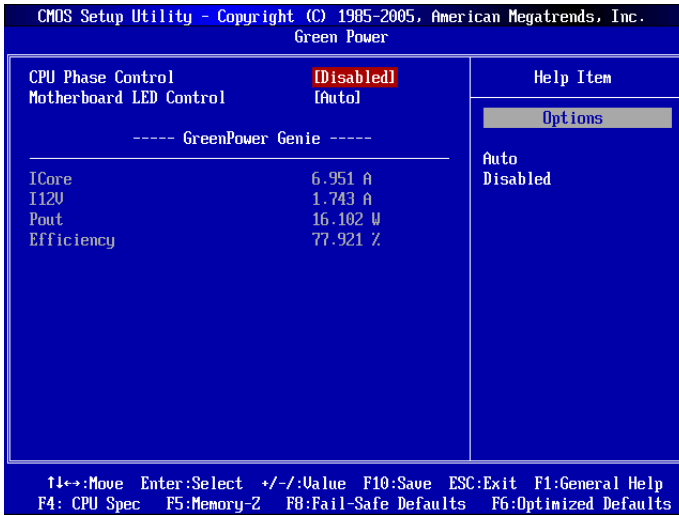

► CPU Phase Control

When set to [Auto], the hardware will auto adjust the CPU power phase according to the loading of CPU to reach the best power saving function.

► Motherboard LED Control

This item is used to enable/ disable the power phase LEDs of the motherboard.

----- GreenPower Genie-----

► ICore/ I12V

These items show the amperage of Core/ 12V. Read only.

► Pout/ Efficiency

These items show the power consumption & efficiency of the system. Read only.

CELL MENU

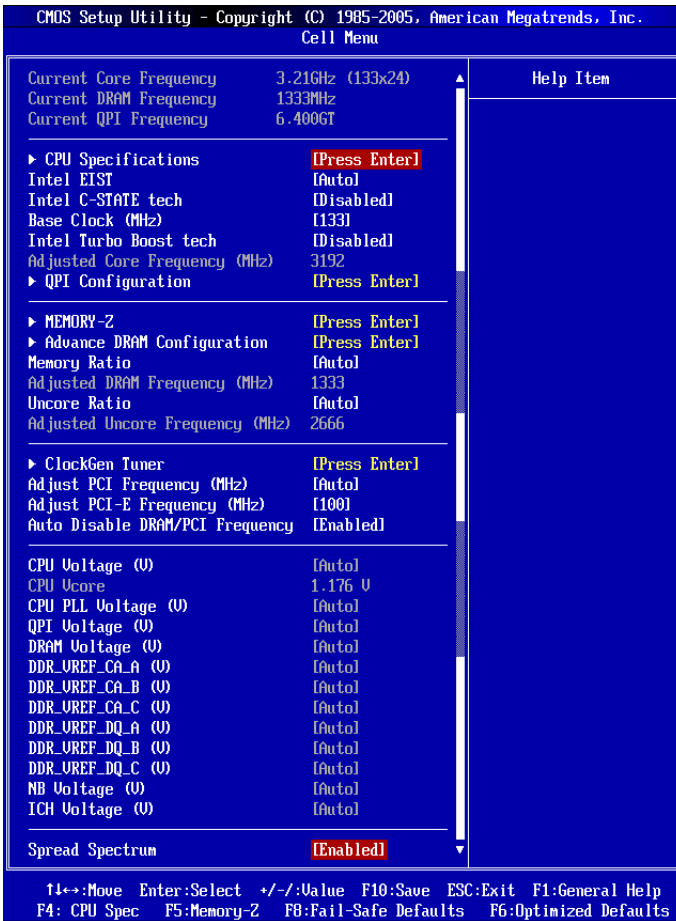

Important

Change these settings only if you are familiar with the chipset.

▶ Current Core / DRAM / QPI Frequency

These items show the current clocks of CPU core, Memory and QPI speed. Read-only.

► CPU Specifications

Press <Enter> to enter the sub-menu and the following screen appears.

CMOS Setup Utility - Copyright (C) 1985-2005, American Megatrends, Inc.		
CPU Specifications		
		Help Item
Genuine Intel(R) CPU	000 @ 3.20GHz	
CPUID/MicroCode	106A4/06	
Core Frequency	3200MHz	
CPU Ratio	24	
CPU Stepping	C0	
Cache L1	128 KB	
Cache L2	1024 KB	
Cache L3	8192 KB	
Core UID	N/A	
Current Core VID	1.176 V	
Core Number	8	
► CPU Technology Support	[Press Enter]	

This sub-menu displays the informations of installed CPU.

► CPU Technology Support

Press <Enter> to enter the sub-menu and the following screen appears.

CMOS Setup Utility - Copyright (C) 1985-2005, American Megatrends, Inc.		
CPU Technology Support		
		Help Item
MMX (TM)	YES	
SSE Extensions	YES	
SSE2 Extensions	YES	
SSE3 Extensions	YES	
SSE4 Extensions	YES	
SSE5 Extensions	N/A	
Page Size Extension (PSE)	YES	
Page Attribute Table (PAT)	YES	
C1E	N/A	
NX	N/A	
TM1	YES	
TM2	YES	
Intel(R) UT	YES	
Intel(R) 64	YES	
Intel(R) EIST	YES	
Hyper-Threading	YES	

This sub-menu displays the technologies that the installed CPU supported.

► Intel EIST

The Enhanced Intel SpeedStep technology allows you to set the performance level of the microprocessor whether the computer is running on battery or AC power. This field will appear after you installed the CPU which support EIST technology.

► Intel C-STATE tech

C-state is a power management state that significantly reduces the power of the processor during idle. This field will appear after you installed the CPU which support c-state technology.

► Base Clock (MHz)

This item allows you to set the CPU Base clock (in MHz).

► Intel Turbo Boost tech

This item will appear when you install a CPU include Intel Turbo Boost technology. This item is used to enable/ disable Intel Turbo Boost technology. For further information please refer to Intel's official website.

► Adjusted Core Frequency (MHz)

It shows the adjusted CPU frequency (Base clock x Ratio). Read-only.

► QPI Configuration

Press <Enter> to enter the sub-menu and the following screen appears.

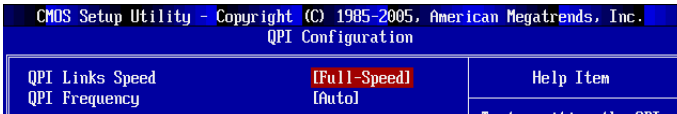

► QPI Links Speed

This item allows you to select the QPI links speed type.

► QPI Frequency

This item allows you to select the QPI frequency.

► MEMORY-Z

Press <Enter> to enter the sub-menu and the following screen appears.

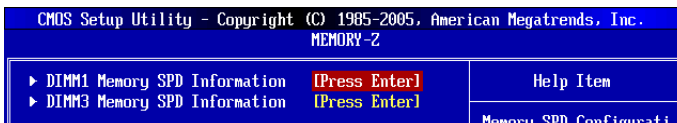

► DIMM1~6 Memory SPD Information

Press <Enter> to enter the sub-menu and the following screen appears.

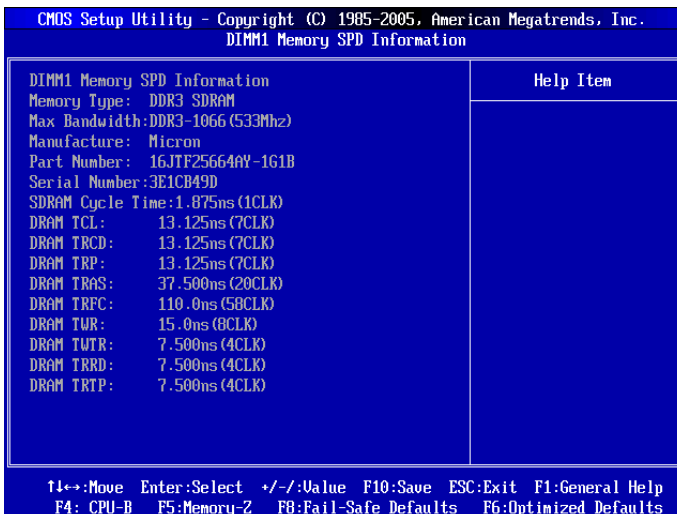

These items display the current status of the current DIMM Memory speed information. They are read only.

► Advance DRAM Configuration

Press <Enter> to enter the sub-menu and the following screen appears.

CMOS Setup Utility - Copyright (C) 1985-2005, American Megatrends, Inc.		
Advance DRAM Configuration		
		Help Item
1N/2N Memory Timing	[Auto]	
CAS Latency (CL)	[Auto]	
tRCD	[Auto]	Also called "Command Rate"; the delay cycle between the memory controller start to
tRP	[Auto]	
tRAS	[Auto]	
Advanced Memory Setting	[Auto]	

► 1N/2N Memory Timing

This item controls the SDRAM command rate. Select [1N] makes SDRAM signal controller to run at 1N (N=clock cycles) rate. Selecting [2N] makes SDRAM signal controller run at 2N rate.

► CAS# Latency (CL)

This controls the CAS latency, which determines the timing delay (in clock cycles) before SDRAM starts a read command after receiving it.

► tRCD

When DRAM is refreshed, both rows and columns are addressed separately. This setup item allows you to determine the timing of the transition from RAS (row address strobe) to CAS (column address strobe). The less the clock cycles, the faster the DRAM performance.

► tRP

This setting controls the number of cycles for Row Address Strobe (RAS) to be allowed to precharge. If insufficient time is allowed for the RAS to accumulate its charge before DRAM refresh, refresh may be incomplete and DRAM may fail to retain data. This item applies only when synchronous DRAM is installed in the system.

► tRAS

This setting determines the time RAS takes to read from and write to memory cell.

► Advanced Memory Setting

Setting to [Auto] enables DRAM timings automatically to be determined by BIOS based on the configurations on the SPD (Serial Presence Detect) EEPROM on the DRAM module.

► Extreme Memory Profile

This item is used to enable/disable the Intel Extreme Memory Profile (XMP). For further information please refer to Intel's official website.

► Memory Ratio

This item allows you to set the memory multiplier.

► Adjusted DRAM Frequency (MHz)

It shows the adjusted Memory frequency. Read-only.

► ClockGen Tuner

Press <Enter> to enter the sub-menu and the following screen appears.



► **CPU Clock Drive/ PCI Express Clock Drive**

These items are used to select the CPU/ PCI Express clock amplitude.

► **CPU CLK Skew/ MCH CLK Skew**

These items are used to select the CPU/ North Bridge chipset clock skew. They can help CPU to reach the higher overclocking performance.

► **Adjust PCI Frequency (MHz)**

This field allows you to select the PCI frequency (in MHz).

► **Adjust PCI-E Frequency (MHz)**

This field allows you to select the PCIe frequency (in MHz).

► **Auto Disable DRAM/PCI Frequency**

When set to [Enabled], the system will remove (turn off) clocks from empty DIMM and PCI slots to minimize the electromagnetic interference (EMI).

► **CPU Voltage (V)/ CPU Vcore/ CPU PLL Voltage (V)/ QPI Voltage (V)/ DRAM Voltage (V)/ DDR_VREF_CA_A (V)/ DDR_VREF_CA_B (V)/ DDR_VREF_CA_C (V)/ DDR_VREF_DQ_A (V)/DDR_VREF_DQ_B (V), DDR_VREF_DQ_C (V)/ NB Voltage (V)/ ICH Voltage (V)**

These items are used to adjust the voltage of CPU, Memory, QPI and chipset.

For CPU Voltage:

The value here is the offset for you to adjust/add based on the current CPU voltage. Please read the real-time CPU voltage in "CPU Vcore" in the "H/W monitor" page. Please note the based CPU Voltage will vary depending on the different CPU you install.

For QPI Voltage:

The value here is the offset for you to adjust/add based on the current QPI voltage. The default based QPI Voltage is from 1.1V to 1.22V, and it will vary depending on the different CPU you install. You can read the QPI voltage in GreenPower Center.

For DRAM Voltage:

According to the Inte CPU spec, DRAM Voltage setting 1.65V may damage the CPU permanently. It is strongly recommended that you install the DRAM with the voltage setting below 1.65V. You can read the DRAM voltage in GreenPower Center.

► **Spread Spectrum**

When the mainboard's clock generator pulses, the extreme values (spikes) of the pulses create EMI (Electromagnetic Interference). The Spread Spectrum function reduces the EMI generated by modulating the pulses so that the spikes of the pulses are reduced to flatter curves. If you do not have any EMI problem, leave the setting at Disabled for optimal system stability and performance. But if you are plagued by EMI, set to Enabled for EMI reduction. Remember to disable Spread Spectrum if you are overclocking because even a slight jitter can introduce a temporary boost in clock speed which may just cause your overclocked processor to lock up.

Important

- *If you do not have any EMI problem, leave the setting at [Disabled] for optimal system stability and performance. But if you are plagued by EMI, select the value of Spread Spectrum for EMI reduction.*
- *The greater the Spread Spectrum value is, the greater the EMI is reduced, and the system will become less stable. For the most suitable Spread Spectrum value, please consult your local EMI regulation.*
- *Remember to disable Spread Spectrum if you are overclocking because even a slight jitter can introduce a temporary boost in clock speed which may just cause your overclocked processor to lock up.*

Important

Failed Overclocking Resolution

This motherboard supports overclocking greatly. However, please make sure your peripherals and components are bearable for some special settings. Any operation that exceeds product specification is not recommended. Any risk or damage resulting from improper operation will not be under our product warranty.

Two ways to save your system from failed overclocking...

- **Reboot**

Press the Power button to reboot the system three times. Please note that, to avoid electric current to affect other devices or components, we suggest an interval of more than 10 seconds among the reboot actions.

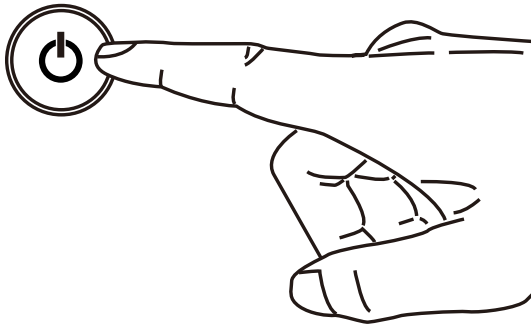

At the fourth reboot, BIOS will determine that the previous overclocking is failed and restore the default settings automatically. Please press any key to boot the system normally when the following message appears on screen.

Warning !!! The previous overclocking had failed,
and system will restore its defaults setting,
Press any key to continue.....

- **Clear CMOS**

Please refer to "Chapter 2" for more information about how to clear CMOS data.

USER SETTINGS

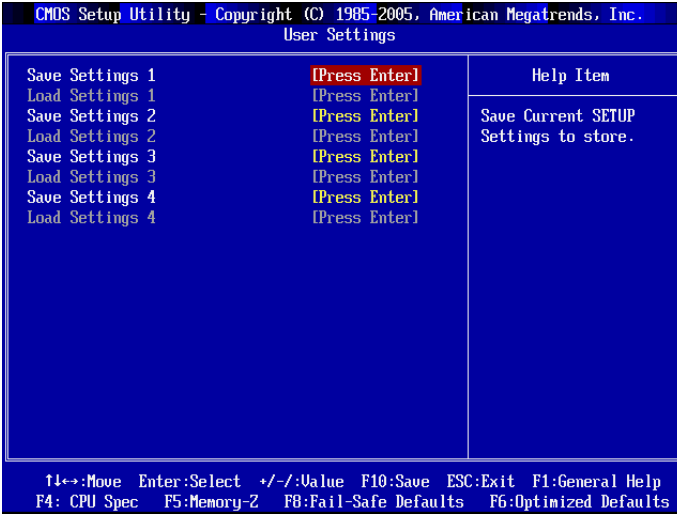

► Save Settings 1/ 2/ 3/ 4

These items are used to save the settings set by yourself to CMOS.

► Load Settings 1/ 2/ 3/ 4

These items are available after you save your settings in Save Settings 1/ 2/ 3/ 4 items , and are used to load the settings from CMOS.

M-FLASH

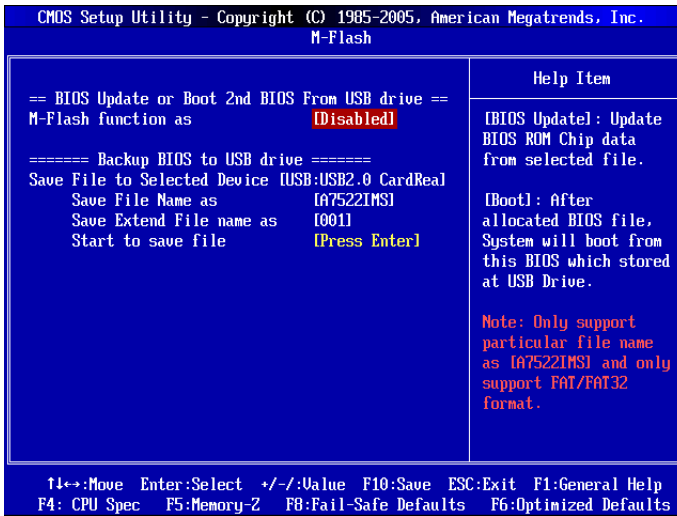

== BIOS Update or Load BIOS From USB drive==

► M-Flash function as

M-Flash function allows you to flash BIOS from USB drive/ storage drive (FAT/ FAT32 format only), or allows the system to boot from the BIOS file inside USB drive (FAT/ FAT32 format only).

- [Disabled] Disable M-Flash function.
- [BIOS Update] Flash BIOS via the USB/ Storage drive directly. Update BIOS ROM chip data from selected file, which is download from official website and must be saved in the root directory of the USB/ Storage drive. It only supports particular file name, which is the official BIOS file name from us.
- [Boot] After allocated particular BIOS file, system will boot from this BIOS file which saved in the root directory of USB drive. System will skip MB ROM chip data and boot with this particular BIOS inside USB drive. Note: this option is for USB drive only.

Important

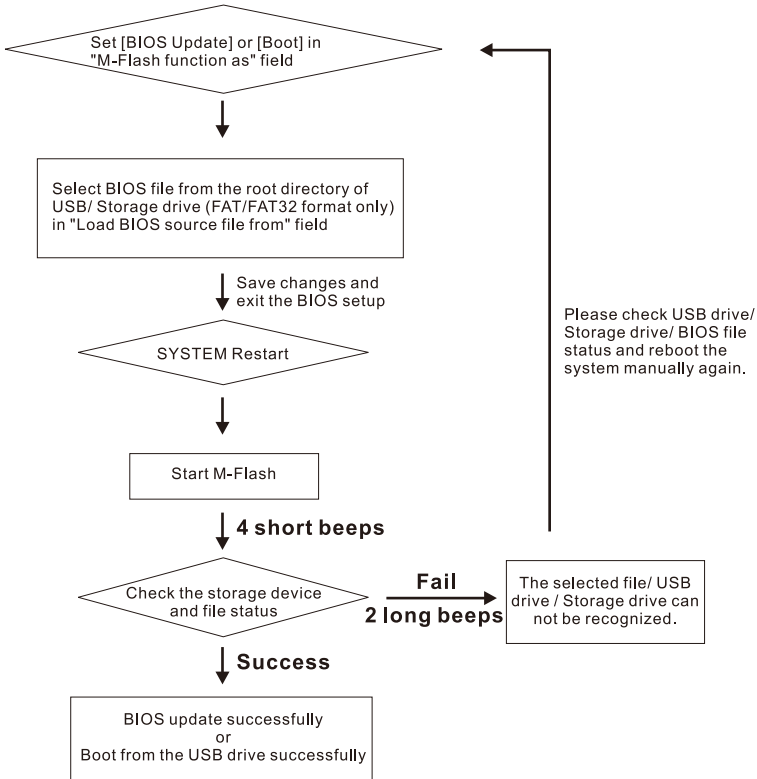

- Please refer to the block diagram below about the M-Flash function.
- Due to the special design of some graphics cards will cause dark screen during M-flash operation, and you may refer the beeps from the system to confirm the current M-flash process.

► Load BIOS source file from

When the M-Flash function as sets to [USB Drive] or [BIOS Update], this item is selectable. Using this item to select particular BIOS file from the USB/ Storage (FAT/32 format only) drive.

== BIOS Data Saving ==

The following fields are used to read the onboard BIOS ROM data, and save it to USB drive/ storage drive.

▶ Save File to Selected Device

Please setup a specific folder in specific USB drive/ storage drive to save BIOS file from BIOS ROM chip data. Note: it only supports FAT/ FAT32 file system drive.

▶ Save File Name as

Please setup a specific name for the BIOS file, which will be saved into the USB drive/ storage drive. Note: we suggest you using the official name as the default name.

▶ Save Extend File name as

Please setup a specific extend name for the BIOS file, which will be saved into the USB drive/ storage drive. Note: we suggest you using [ROM] as default name.

▶ Start to save file

Press "Enter" and select "OK" the system will start to save the onboard ROM chip data to the selected USB drive/ storage drive.

LOAD FAIL-SAFE/ OPTIMIZED DEFAULTS

The two options on the main menu allow users to restore all of the BIOS settings to the default Fail-Safe or Optimized values. The Optimized Defaults are the default values set by the mainboard manufacturer specifically for optimal performance of the mainboard. The Fail-Safe Defaults are the default values set by the BIOS vendor for stable system performance.

When you select Load Fail-Safe Defaults, a message as below appears:



Selecting Ok and pressing Enter loads the BIOS default values for the most stable, minimal system performance.

When you select Load Optimized Defaults, a message as below appears:



Selecting Ok and pressing Enter loads the default factory settings for optimal system performance.

Appendix A

Realtek Audio

The Realtek audio provides 10-channel DAC that simultaneously supports 7.1 sound playback and 2 channels of independent stereo sound output (multiple streaming) through the Front-Out-Left and Front-Out-Right channels.

INSTALLING THE REALTEK HD AUDIO DRIVER

You need to install the HD audio driver for Realtek audio codec to function properly before you can get access to 2-, 4-, 6-, 8- channel or 7.1+2 channel audio operations. Follow the procedures described below to install the drivers for different operating systems.

Installation for Windows® XP

For Windows® XP, you must install Windows® XP Service Pack3 or later before installing the driver.

The following illustrations are based on Windows® XP environment and could look slightly different if you install the drivers in different operating systems.

1. Insert the application DVD into the DVD-ROM drive. The setup screen will automatically appear.
2. Click Realtek HD Audio Drivers button.



Important

The HD Audio Configuration software utility is under continuous update to enhance audio applications. Hence, the program screens shown here in this section may be slightly different from the latest software utility and shall be held for reference only.

3. Click Next to install the Realtek High Definition Audio Driver.

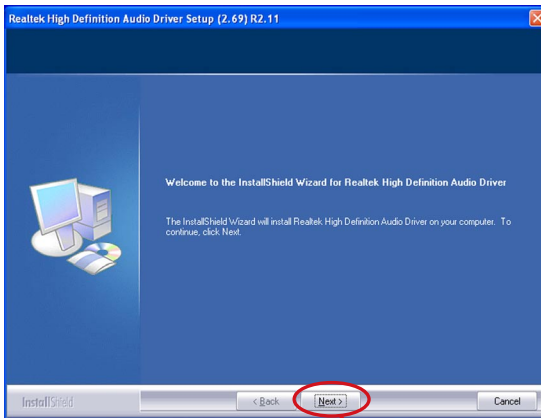

Click here

4. Click Finish to restart the system.

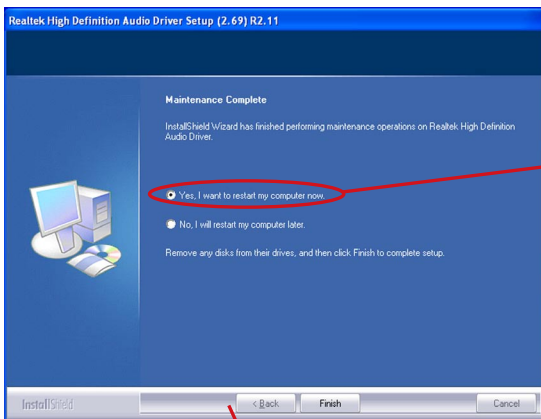

Select this option

Click here

SOFTWARE CONFIGURATION

After installing the audio driver, you are able to use the 2-, 4-, 6- or 8- channel audio feature now. Click the audio icon  from the system tray at the lower-right corner of the screen to activate the HD Audio Configuration. It is also available to enable the audio driver by clicking the Realtek HD Audio Manager from the Control Panel.

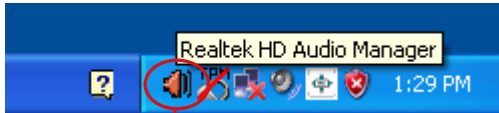

Double click

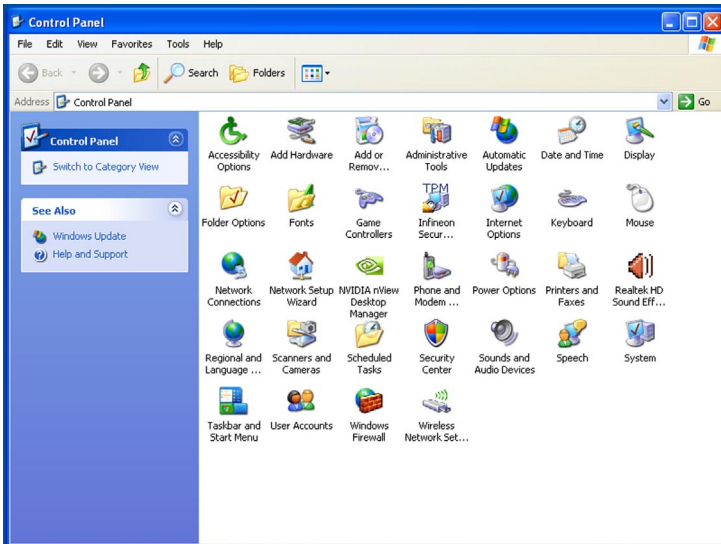

Sound Effect

Here you can select a sound effect you like from the **Environment** list.



Environment Simulation

You will be able to enjoy different sound experience by pulling down the arrow, totally 23 kinds of sound effect will be shown for selection. Realtek HD Audio Sound Manager also provides five popular settings "Stone Corridor", "Bathroom", "Sewer pipe", "Arena" and "Auditorium" for quick enjoyment.

You may choose the provided sound effects, and the equalizer will adjust automatically. If you like, you may also load an equalizer setting or make an new equalizer setting to save as an new one by using the "Load EQ Setting" and "Save Preset" button, click "Reset EQ Setting" button to use the default value, or click "Delete EQ Setting" button to remove a preset EQ setting.

There are also other pre-set equalizer models for you to choose by clicking "Others" under the Equalizer part.

Equalizer Selection

Equalizer frees users from default settings; users may create their own preferred settings by utilizing this tool.

10 bands of equalizer, ranging from 100Hz to 16KHz.

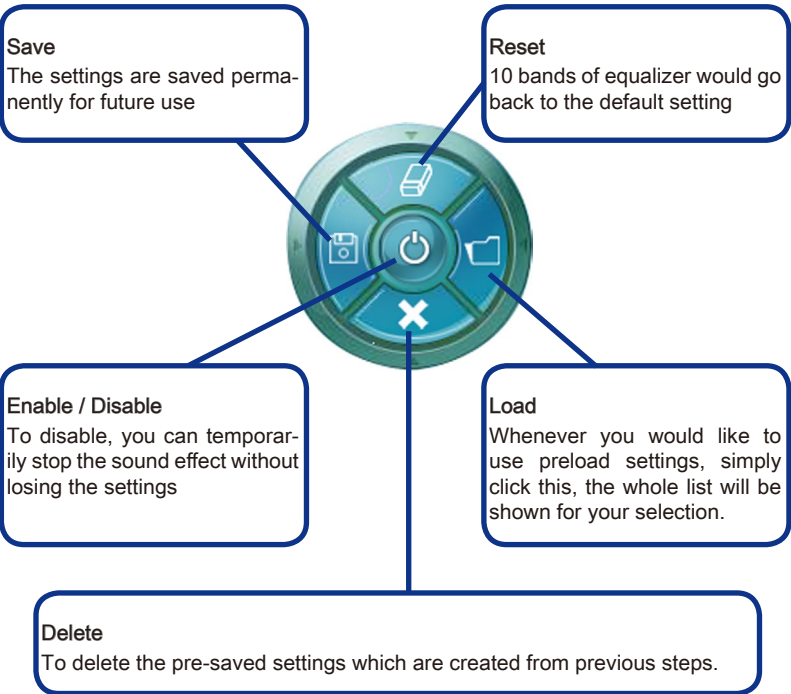
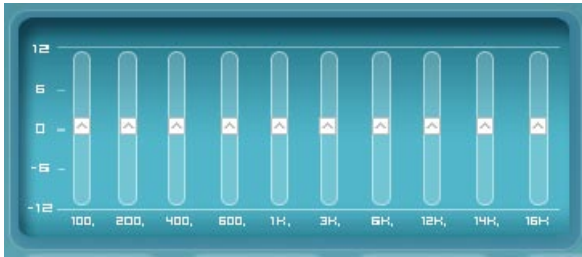

Frequently Used Equalizer Setting

Realtek recognizes the needs that you might have. By leveraging our long experience at audio field, Realtek HD Audio Sound Manager provides you certain optimized equalizer settings that are frequently used for your quick enjoyment.

[How to Use It]

Other than the buttons “Pop”, “Live”, “Club” & “Rock” shown on the page, to pull down the arrow in “Others” you will find more optimized settings available to you.

Karaoke Mode

Karaoke mode brings Karaoke fun back home. Simply using the music you usually play, Karaoke mode can help you eliminate the vocal of the song or adjust the key to accommodate your range.

1. Vocal Cancellation: Single click on “Voice Cancellation” the vocal of the song would be eliminated, while the background music is still in place, and you can be that singer!
2. Key Adjustment: Using “Up / Down Arrow” to find a key which better fits your vocal range.

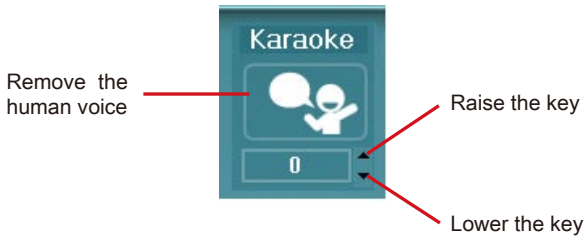

Mixer

In the Mixer part, you may adjust the volumes of the rear and front panels individually.

■ Adjust Volume

You can adjust the volume of the speakers that you plugged in front or rear panel by select the Realtek HD Audio rear output or Realtek HD Audio front output items.



Important

Before set up, please make sure the playback devices are well plugged in the jacks on the rear or front panel. The Realtek HD Audio front output item will appear after you plugging the speakers into the jacks on the front panel.

■ Multi-Stream Function

Realtek audio supports an outstanding feature called Multi-Stream, which means you may play different audio sources simultaneously and let them output respectively from the indicated rear panel or front panel. This feature is very helpful when 2 people are using the same computer together for different purposes.

Click the  button and the Mixer ToolBox menu will appear. Then check the Enable playback multi-streaming and click OK to save the setup.

Important

You have to plug audio device into the jacks on the rear and front panel first before enable the multi-stream function.

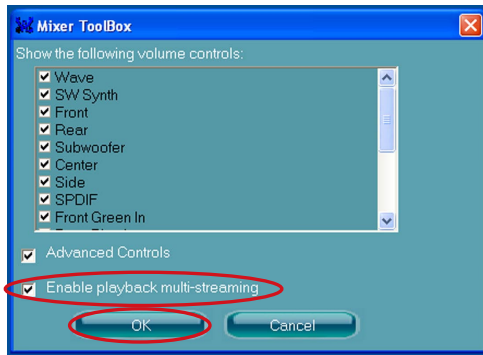

When you are playing the first audio source (for example: use Windows Media Player to play DVD/VCD), the output will be played from the rear panel, which is the default setting.

Then you must to select the **Realtek HD Audio 2nd output** from the scroll list first, and use a different program to play the second audio source (for example: use Winamp to play MP3 files). You will find that the second audio source (MP3 music) will come out from the Line-Out audio jack of Front Panel.



■ Playback control



Playback device

This function is to let you freely decide which ports to output the sound. And this is essential when multi-streaming playback enabled.

- Realtek HD Audio Rear Output
- Realtek HD Audio Front Output

Mute

You may choose to mute single or multiple volume controls or to completely mute sound output.

Tool

- Show the following volume controls

This is to let you freely decide which volume control items to be displayed.

- Advanced controls
- Enable playback multi-streaming

With this function, you will be able to have an audio chat with your friends via headphone (stream 1 from front panel) while still have music (stream 2 from back panel) in play. At any given period, you can have maximum 2 streams operating simultaneously.



■ Recording control



Mute

You may choose to mute single or multiple volume controls or to completely mute sound input.

Tool

- Show the following volume controls

This is to let you freely decide which volume control items to be displayed.

- Enable recording multi-streaming

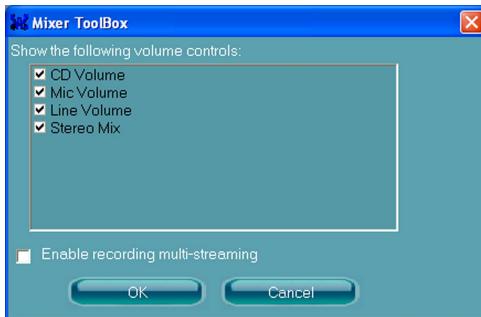

Important

Realtek audio allows you to record the CD, Line, Mic and Stereo Mix channels simultaneously, frees you from mixing efforts. At any given period, you may choose 1 of the following 4 channels to record.

Audio I/O

In this tab, you can easily configure your multi-channel audio function and speakers. You can choose a desired multi-channel operation here.

- Headphone for the common headphone
- 2CH Speaker for Stereo-Speaker Output
- 4CH Speaker for 4-Speaker Output
- 6CH Speaker for 5.1-Speaker Output
- 8CH Speaker for 7.1-Speaker Output



■ Speaker Configuration:

1. Plug the speakers in the corresponding jack.
2. Dialogue “connected device” will pop up for your selection. Please select the device you have plugged in.
 - If the device is being plugged into the correct jack, you will be able to find the icon beside the jack changed to the one that is same as your device.
 - If not correct, Realtek HD Audio Manager will guide you to plug the device into the correct jack.

■ Connector Settings

Click  to access connector settings.



Disable front panel jack detection (optional)

Jack detection function only works with HD audio front panel. Please check if front jacks on your system are so-called AC'97 jacks. If so, please check this item to disable front panel jack detection.

Mute rear panel output when front headphone plugged in.

Enable auto popup dialogue, when device has been plugged in

Once this item checked, the dialog "Connected device" would automatically pop up when device plugged in.

S/PDIF

Short for Sony/Philips Digital Interface, a standard audio file transfer format. S/PDIF allows the transfer of digital audio signals from one device to another without having to be converted first to an analog format. Maintaining the viability of a digital signal prevents the quality of the signal from degrading when it is converted to analog.

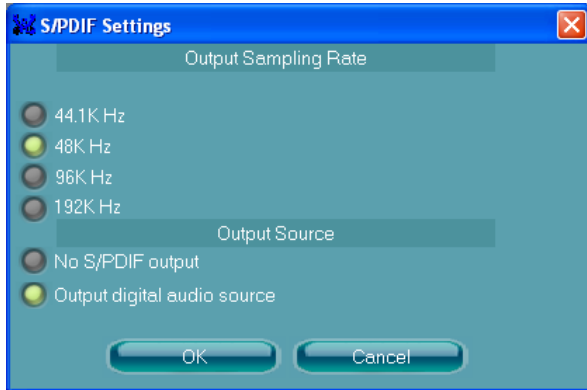

Output Sampling Rate

44.1KHz: This is recommend while playing CD.

48KHz: This is recommended while playing DVD or Dolby.

96KHz: This is recommended while playing DVD-Audio.

192KHz: This is recommended while playing High quality Audio.

Output Source

Output digital audio source: The digital audio format (such as .wav, .mp3, .midi etc) will come out through S/PDIF-Out.

S/PDIF-in to S/PDIF -out pass though mode: The data from S/PDIF-In can be real-time played from S/PDIF-Out.

Test Speakers

You can select the speaker by clicking it to test its functionality. The one you select will light up and make testing sound. If any speaker fails to make sound, then check whether the cable is inserted firmly to the connector or replace the bad speakers with good ones. Or you may click the **auto test**  button to test the sounds of each speaker automatically.

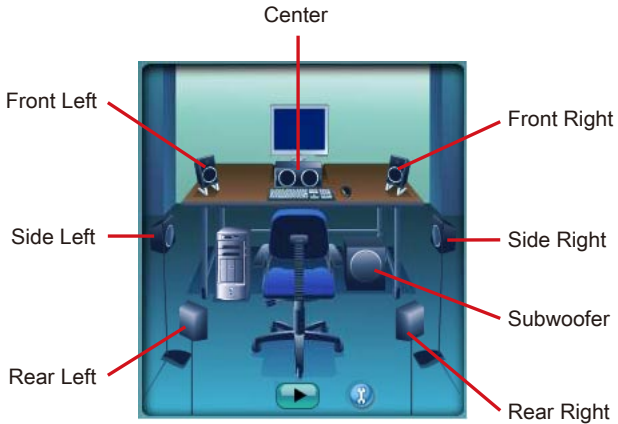

Microphone

In this tab you may set the function of the microphone. Select the **Noise Suppression** to remove the possible noise during recording, or select **Acoustic Echo Cancellation** to cancel the acoustic echo during recording.

Acoustic Echo Cancellation prevents playback sound from being recorded by microphone together with your sound. For example, you might have chance to use VOIP function through Internet with your friends. The voice of your friend will come out from speakers (playback). However, the voice of your friend might also be recorded into your microphone then go back to your friend through Internet. In that case, your friend will hear his/her own voice again. With AEC(Acoustic Echo Cancellation) enabled at your side, your friend can enjoy the benefit with less echo.



3D Audio Demo

In this tab you may adjust your 3D positional audio before playing 3D audio applications like gaming. You may also select different environment to choose the most suitable environment you like.



Information

In this tab it provides some information about this HD Audio Configuration utility, including Audio Driver Version, DirectX Version, Audio Controller & Audio Codec. You may also select the language of this utility by choosing from the **Language** list.



Also there is a selection **Show icon in system tray**. Switch it on and an icon  will show in the system tray. Right-click on the icon and the **Audio Accessories** dialogue box will appear which provides several multimedia features for you to take advantage of.



HARDWARE SETUP

Connecting the Speakers

When you have set the Multi-Channel Audio Function mode properly in the software utility, connect your speakers to the correct phone jacks in accordance with the setting in software utility.

- 2-Channel Mode for Stereo-Speaker Output

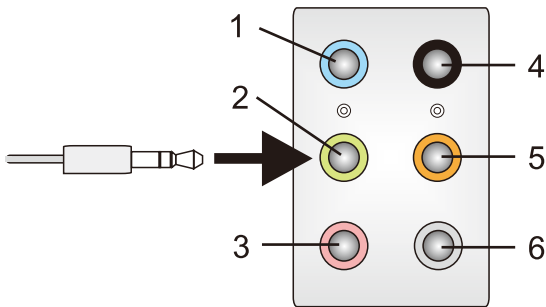

- 1] Line In
- 2] Line Out (Front channels)
- 3] MIC
- 4] No function
- 5] No function
- 6] No function

■ 4-Channel Mode for Stereo-Speaker Output

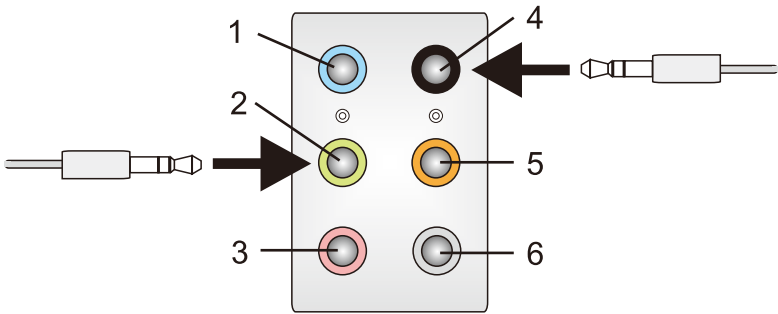

- 1] Line In
- 2] Line Out (Front channels)
- 3] MIC
- 4] Line Out (Rear channels)
- 5] No function
- 6] No function

■ 6-Channel Mode for Stereo-Speaker Output

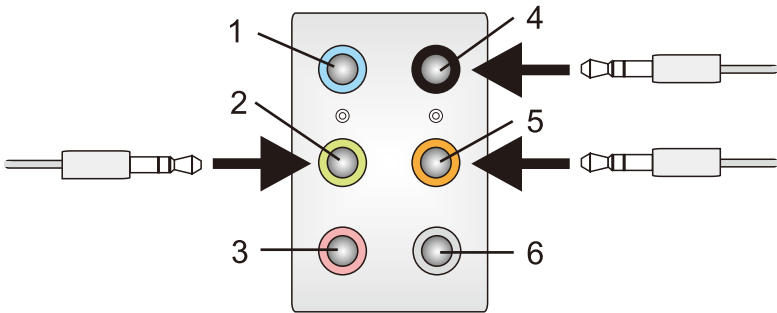

- 1] Line In
- 2] Line Out (Front channels)
- 3] MIC
- 4] Line Out (Rear channels)
- 5] Line Out (Center and Subwoofer channel)
- 6] No function

■ 8-Channel Mode for Stereo-Speaker Output

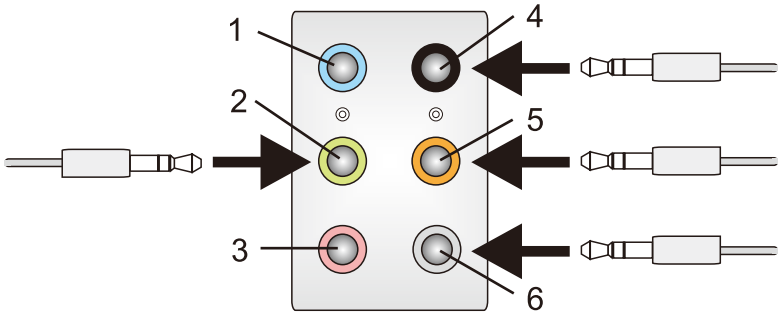

- 1] Line In
- 2] Line Out (Front channels)
- 3] MIC
- 4] Line Out (Rear channels)
- 5] Line Out (Center and Subwoofer channel)
- 6] Line Out (Side channels)

Important

To enable 7.1 channel audio-out function on Vista operating system, you have to install the Realtek Audio Driver. Or, the mainboard will support 5.1 channel audio-out only.

Appendix B

Overclocking Center

Overclocking Center, the most useful and powerful utility that MSI has spent much research and efforts to develop, helps users to monitor or configure the hardware status of MSI Mainboard in windows, such as CPU clock, voltage, fan speed and temperature.

Before you install the Overclocking Center, please make sure the system has meet the following requirements:

1. 256MB system memory.
2. CD-ROM drive for software installation.
3. Operation system: Windows XP or up.
4. DotNet Frame Work 2.0

ACTIVATING OVERCLOCKING CENTER

Once you have your Overclocking Center installed (locate the setup source file in the setup CD accompanying with your mainboard, path: **Utility** → **MSI Utility** → **Overclocking Center**), it will have a short cut icon on the desktop, and a short cut path in your “Start-up” menu. You may double-click on each icon to activate Overclocking Center.

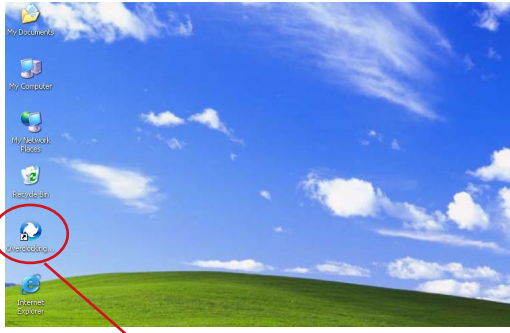

short-cut icon on the desktop

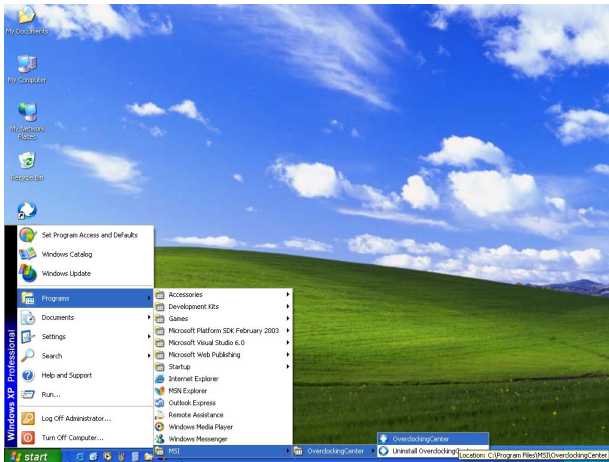

short-cut path in the start-up menu
(path: Start-->Program Files-->MSI-->Overclocking Center-->Overclocking Center)

SYSTEM INFO

In the System Info screen, you can read the informations of mainboard/ memory/ PCI.

Motherboard

Click Motherboard to read the informations of mainboard, mainboard BIOS, installed CPU and installed graphics card.



Memory

Click Memory to read the information of each memory DIMM slot. You can select a DIMM slot you want to read from the SPD list.



PCI

Click PCI to read the information of devices on the mainboard.

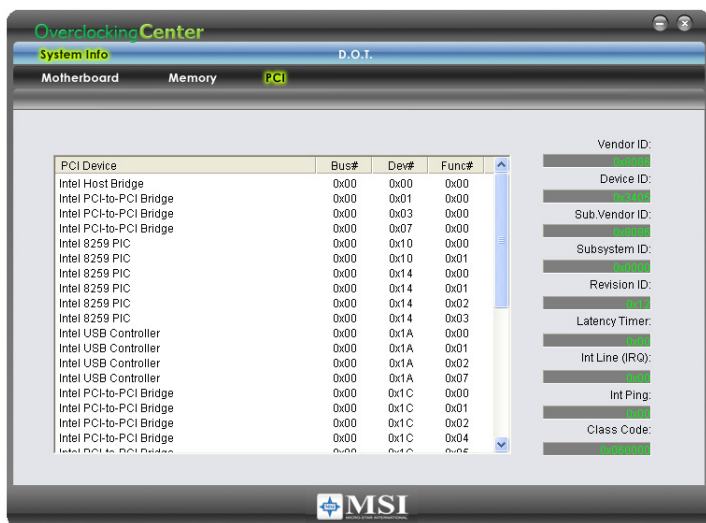

DOT

Click DOT to enter the DOT screen. In DOT, you can select the basic setting to reach optimal performance in Basic menu or you can adjust advanced values for overclocking in Advance menu.

Basic

In the Basic menu, it provides one default setting and five common settings for different environments. You may choose one of the settings that you need. The settings in Basic menu are not adjustable.



Important

You may change the values of each environment setting/ default setting in Advance menu. Please refer the following section for more details.

Advance

In the Advance menu, you can adjust the values for each environment setting/ default setting. Click the Cooling/ Silence/ Default/ Game/ Cinema button to enter it's setting menu. Please refer to the following descriptions to adjust the values and save them.

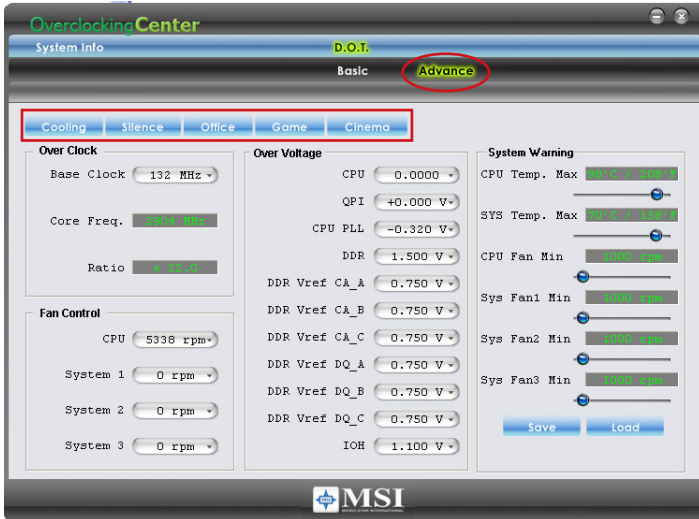

In each setting menu, you can select desired values for manual overclocking. Simply click the right side of the button which arranges an arrow sign, and a drop-down menu will appear below the button, then select a value.

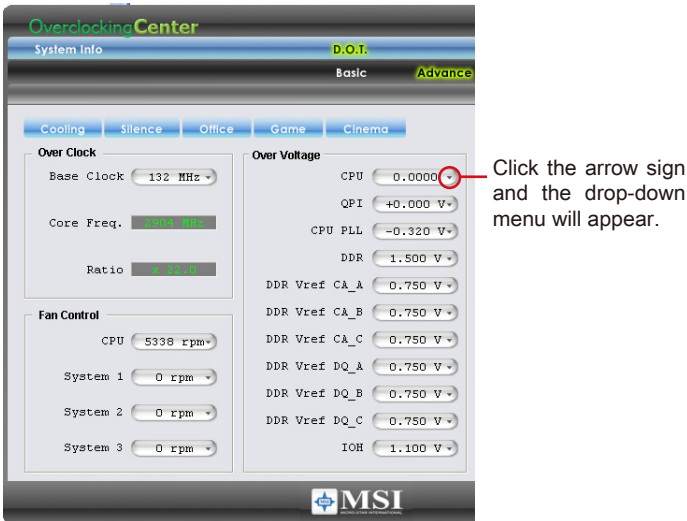

In the “System Warning” block, you can set the maximum CPU/ system temperature and the minimum CPU/ system fan speed by using the scroll bar. The system will pop-up a warning message to warning you when the temperature/ fan speed is over/ lower the values you set.

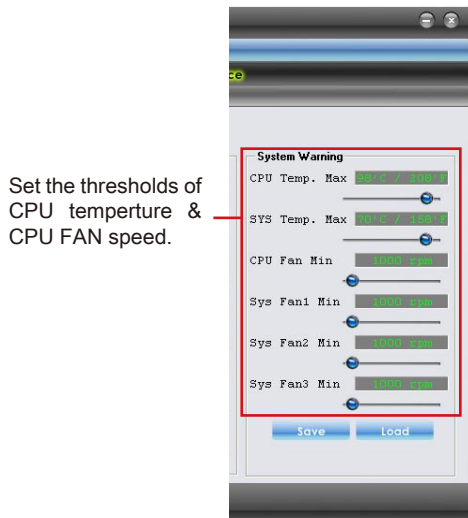

Overclocking Center

After you adjust the values in setting menu, you can save it for future use.



Click the Save button, and enter a name in the empty box. Then, click Save button again to save the settings.

Important

It provides you to save up to 20 user settings.

Click the Load button and choose a saved user setting to load the settings for the system.

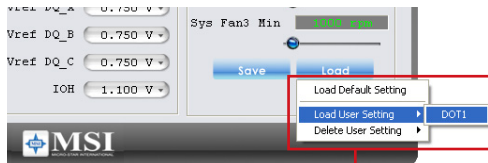

Click the Load button, and choose a saved user setting.

Important

Every time you turn-off the system, the settings will be restored to the factory default. If you want to use the saved settings, you have to load it after entering the operating system every time.

Appendix C

Intel ICH10R SATA RAID

This appendix will assist users in configuring and enabling RAID functionality on platforms

INTRODUCTION

The ICH10R provides a hybrid solution that combines 6 independent SATAII ports for support of up to 6 Serial ATAII (Serial ATAII RAID) drives.

Serial ATAII (SATAII) is the latest generation of the ATA interface. SATA hard drives deliver blistering transfer speeds up to 3 Gb/s. Serial ATA uses long, thin cables, making it easier to connect your drive and improving the airflow inside your PC. The most outstanding features are:

1. Supports 3 Gb/s transfers with CRC error checking.
2. Supports Hot-plug-n-play feature.
3. Data handling optimizations including tagged command queuing, elevator seek and packet chain command.

Intel® ICH10R offers RAID level 0 (Striping), RAID level 1 (Mirroring and Duplexing), RAID level 5 (Block Interleaved Distributed Parity), RAID level 10 (A Stripe of Mirrors) , Intel® Matrix Storage Technology and Intel® Rapid Recover Technology.

RAID 0 breaks the data into blocks which are written to separate hard drives. Spreading the hard drive I/O load across independent channels greatly improves I/O performance.

RAID 1 provides data redundancy by mirroring data between the hard drives and provides enhanced read performance.

RAID 5 Provides data striping at the byte level and also stripe error correction information. This results in excellent performance and good fault tolerance. Level 5 is one of the most popular implementations of RAID.

RAID 10 Not one of the original RAID levels, multiple RAID 1 mirrors are created, and a RAID 0 stripe is created over these.

Intel® Matrix RAID Technology is the advanced ability for two RAID volumes to share the combined space of two hard drives being used in unison.

Intel® Rapid Recover Technology utilizes RAID 1 functionality to copy data from a designated Master drive to a designated Recovery drive. The size of the Master drive must be less than or equal to the size of the Recovery drive. When a Recovery volume is created, complete capacity of the Master drive will be used as the Master volume. Only one Recovery Volume can exist on a system. There are 2 methods of updating the data on the Master to the Recovery drive. They are Continuous Update Policy and On Request Update Policy.

Important

The least number of hard drives for RAID 0, RAID 1, Recovery or Matrix mode is 2. The least number of hard drives for RAID 10 mode is 4. And the least number of hard drives for RAID 5 mode is 3.

All the information/ volumes/ pictures listed in your system might differ from the illustrations in this appendix.

BIOS CONFIGURATION

The Intel Matrix Storage Manager Option ROM should be integrated with the system BIOS on all motherboards with a supported Intel chipset. The Intel Matrix Storage Manager Option ROM is the Intel RAID implementation and provides BIOS and DOS disk services. Please use <Ctrl> + <I> keys to enter the "Intel® RAID for Serial ATA" status screen, which should appear early in system boot-up, during the POST (Power-On Self Test). Also, you need to enable the RAID function in BIOS to create, delete and reset RAID volumes.

Using the Intel Matrix Storage Manager Option ROM

Creating, Deleting and Resetting RAID Volumes:

The Serial ATA RAID volume may be configured using the RAID Configuration utility stored within the Intel RAID Option ROM. During the Power-On Self Test (POST), the following message will appear for a few seconds:



Important

The "Device Model", "Serial #" and "Size" in the following example might be different from your system.

```
Intel(R) Matrix Storage Manager option ROM v8.5.0.1013 ICH10R wRAID5
Copyright(C) 2003-08 Intel Corporation, All Rights Reserved.'

RAID Volumes
None de fined.

Physical Disks::
Port Device Model Serial # Size Type/Status(Vol ID)
0 HDS722580VLSA80 VNRB3EC20549SL 76.7GB Non-RAID Disk
1 HDS722580VLSA80 VNRB3EC20559SL 76.7GB Non-RAID Disk
2 HDS722580VLSA80 VNRB3EC20569SL 76.7GB Non-RAID Disk
3 HDS722580VLSA80 VNRB3EC20579SL 76.7GB Non-RAID Disk

Press <CTRL-I> to enter Configuration Utility..
```

After the above message shows, press <Ctrl> and <I> keys simultaneously to enter the RAID Configuration Utility.

Important

The following procedure is only available with a newly-built system or if you are reinstalling your OS. It should not be used to migrate an existing system to RAID.

After pressing the <Ctrl> and <I> keys simultaneously, the following window will appear:

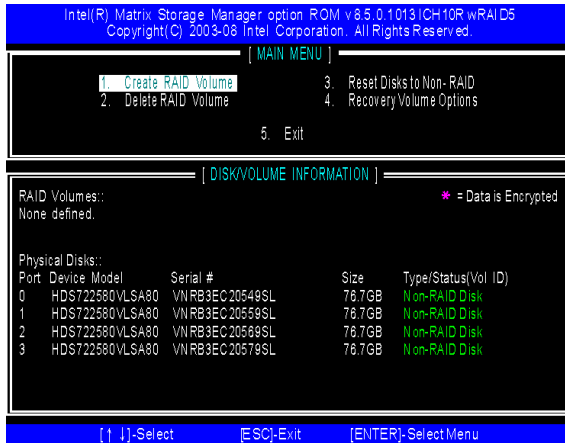

■ Create RAID Volume

1. Select option 1 "Create RAID Volume" and press <Enter> key. The following screen appears. Then in the Name field, specify a RAID Volume name and then press the <TAB> or <Enter> key to go to the next field.
2. Use the arrow keys to select the RAID level best suited to your usage model in RAID Level.

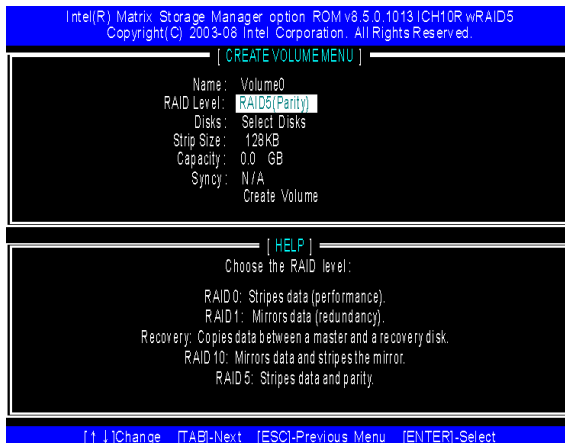

- In the Disk field, press <Enter> key and the following screen appears. Use <Space> key to select the disks you want to create for the RAID volume, then click <Enter> key to finish selection.

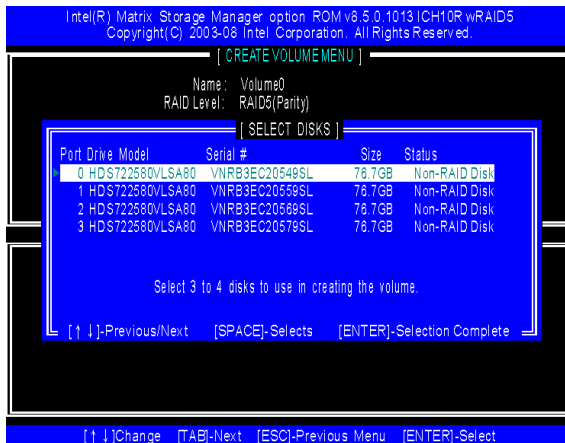

- Then select the strip value for the RAID array by using the “upper arrow” or “down arrow” keys to scroll through the available values, and pressing the <Enter> key to select and advance to the next field. The available values range from 4KB to 128 KB in power of 2 increments. The strip value should be chosen based on the planned drive usage. Here are some typical values: RAID0 -128KB / RAID10 - 64KB / RAID5 - 64KB.
- Then select the capacity of the volume in the Capacity field. The default value is the maximum volume capacity of the selected disks.

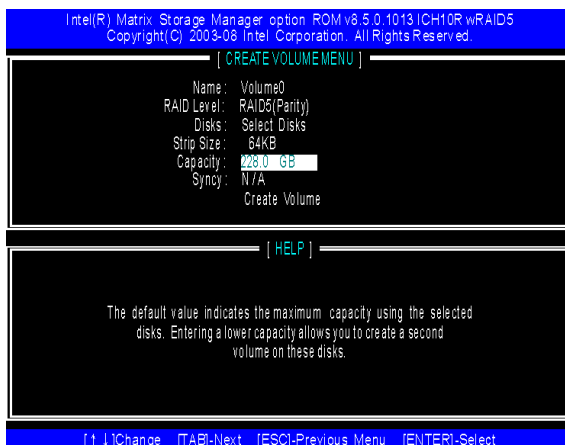

Important

Since you want to create two volumes (Intel Matrix RAID Technology), this default size (maximum) needs to be reduced. Type in a new size for the first volume. As an example: if you want the first volume to span the first half of the two disks, re-type the size to be half of what is shown by default. The second volume, when created, will automatically span the remainder of two hard drives.

- Then the following screen appears for you to confirm if you are sure to create the RAID volume. Press <Y> to continue.

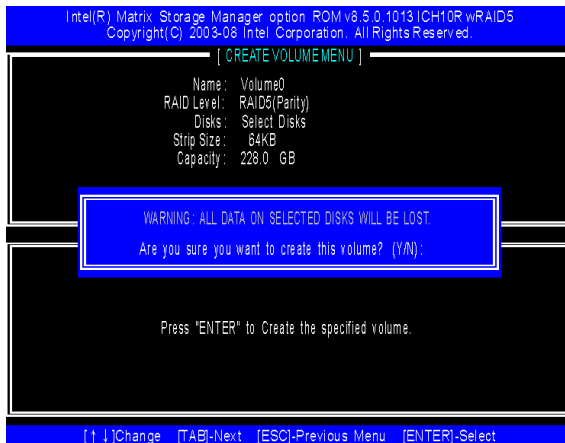

- Then the following screen appears to indicate that the creation is finished.

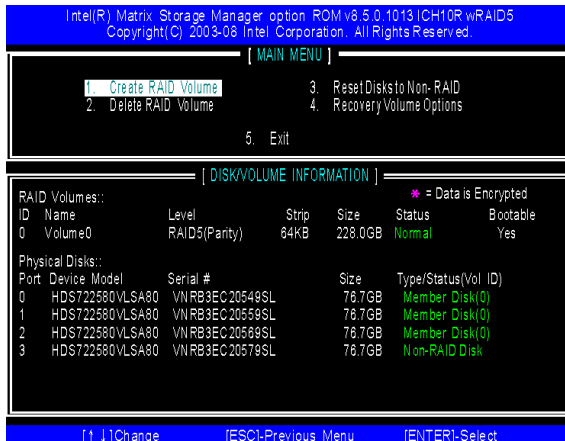

■ Delete RAID Volume

Here you can delete the RAID volume, but please be noted that all data on RAID drives will be lost.

Important

If your system currently boots to RAID and you delete the RAID volume in the Intel RAID Option ROM, your system will become unbootable.

Select option 2 **Delete RAID Volume** from the main menu window and press <Enter> key to select a RAID volume for deletion. Then press <Delete> key to delete the selected RAID volume. The following screen appears.

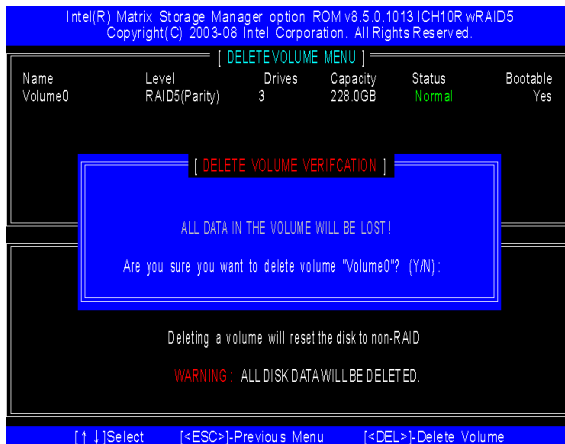

Press <Y> key to accept the volume deletion.

Reset Disks to Non-RAID

Select option 3 Reset Disks to Non-RAID and press <Enter> to delete the RAID volume and remove any RAID structures from the drives. The following screen appears:



Press <Y> key to accept the selection.

Important

- You will lose all data on the RAID drives and any internal RAID structures when you perform this operation.
- Possible reasons to “Reset Disks to Non-RAID” could include issues such as incompatible RAID configurations or a failed volume or failed disk.

■ Recovery Volume Options

Select option 4 Recovery Volume Options and press <Enter> to change recovery volume mode. The following screen appears:

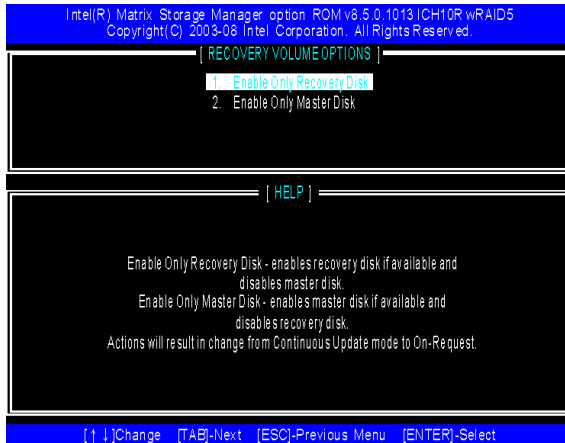

Recovery mode will change from Continuous Update to On-Request after you enable "Only Recovery Disk" or "Only Master Disk".

INSTALLING DRIVER

Install Driver in Windows Vista / XP

?New Windows Vista / XP Installation

The following details the installation of the drivers while installing operating system.

1. When you start installing Windows XP, you may encounter a message stating, "Setup could not determine the type of one or more mass storage devices installed in your system". If this is the case, then you are already in the right place and are ready to supply the driver. If this is not the case, then press F6 when prompted at the beginning of Windows setup.
2. Press the "S" key to select "Specify Additional Device".
3. You should be prompted to insert a floppy disk containing the Intel® RAID driver into the A: drive.

Note: For Windows XP, you can use the USB floppy drive only.

For Windows Vista you can use CD/ DVD/ USB drive.

Important

Please follow the instruction below to make an "Intel® RAID Driver" for yourself.

1. Insert the MSI CD into the CD-ROM drive.
 2. Click the "Browse CD" on the Setup screen.
 3. Copy all the contents in \\IDE\Intel\ICH10R\Floppy to a formatted floppy diskette.
 4. The driver diskette for Intel® ICH10R RAID Controller is done.
-
4. For Windows Vista:
During the Operating system installation, after selecting the location to install Vista click on "Load Driver" button to install a third party SCSI or RAID driver.
 5. When prompted, insert the floppy disk or media (CD/DVD or USB) you created in step 3 and press Enter.
 6. You should be shown a list of available SCSI Adapters.
 7. Select the appropriate Intel RAID controller and press ENTER.
 8. The next screen should confirm that you have selected the Intel® RAID controller. Press ENTER again to continue.
 9. You have successfully installed the Intel® Matrix Storage Manager driver, and Windows setup should continue.
 10. Leave the disk in the floppy drive until the system reboots itself. Windows setup will need to copy the files from the floppy again after the RAID volume is formatted, and Windows setup starts copying files.

■ Existing Windows Vista/ XP Driver Installation

1. Insert the MSI CD into the CD-ROM drive.
2. The CD will auto-run and the setup screen will appear.
3. Under the Driver tab, click on Intel IAA RAID Edition.
4. The drivers will be automatically installed.

■ Confirming Windows Vista/ XP Driver Installation

1. From Windows Vista/ XP, open the Control Panel from My Computer followed by the System icon.
2. Choose the Hardware tab, then click the Device Manager tab.
3. Click the "+" in front of the SCSI and RAID Controllers hardware type. The driver Intel(R) ICH10R SATA RAID Controller should appear.

INSTALLING SOFTWARE

Install Intel Matrix Storage Console

The Intel Application Accelerator RAID Edition driver may be used to operate the hard drive from which the system is booting or a hard drive that contains important data. For this reason, you cannot remove or un-install this driver from the system after installation; however, you will have the ability to un-install all other non-driver components.

Insert the MSI CD and click on the **Intel IAA RAID Editor** to install the software.



Click on this item

The InstallShield Wizard will begin automatically for installation showed as following:

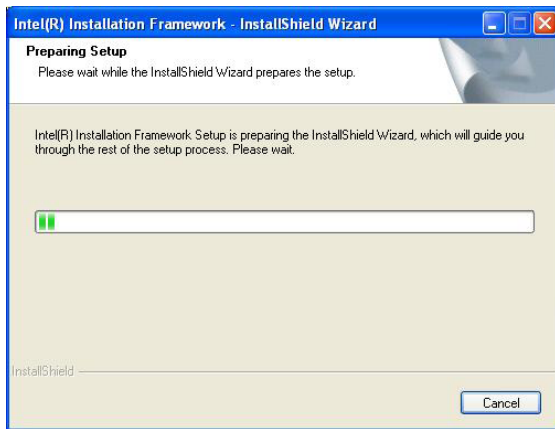

Click on the Next button to proceed the installation in the welcoming window.



The window shows the components to be installed. Click Next button to continue.

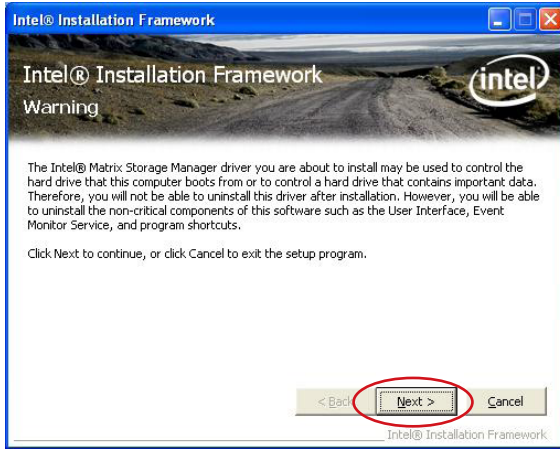

After reading the license agreement in the following window, click Yes button to continue.

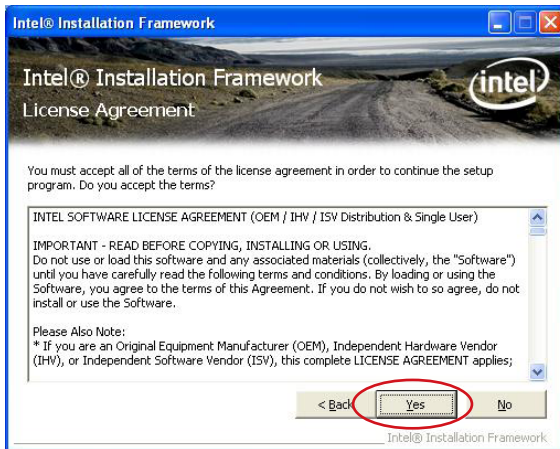

The following window appears to show the Readme File Information. It shows the system requirements and installation information.

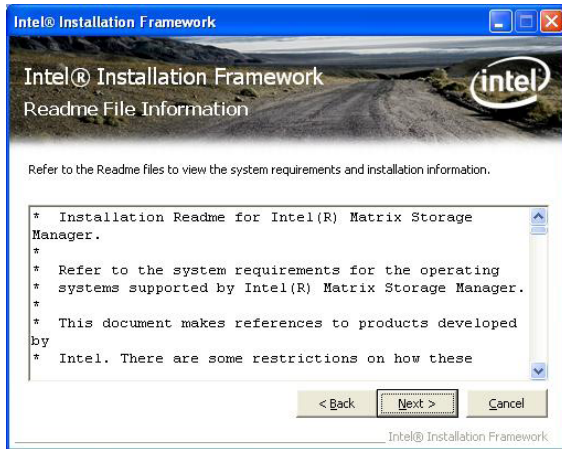

Once the installation is complete, the following window appears.

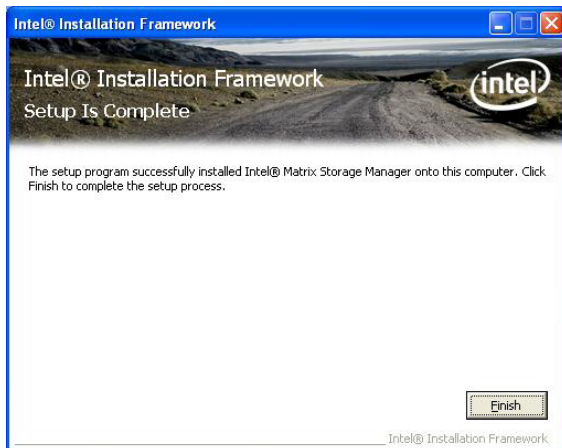

RAID MIGRATION INSTRUCTIONS

The Intel Matrix Storage Console offers the flexibility to upgrade from a single Serial ATA (SATA) hard drive to RAID configuration when an additional SATA hard drive is added to the system. This process will create a new RAID volume from an existing disk. However, several important steps must be followed at the time the system is first configured in order to take advantage of RAID when upgrading to a second SATA hard drive:

1. BIOS must be configured for RAID before installing Windows on the single SATA hard drive. Refer to “BIOS section” properly setting.
2. Install the Intel Application Accelerator RAID Driver during Windows Setup. Refer to “Installing Software” for instructions on installing the driver during Windows Setup.
3. Install the Intel Matrix Storage Console after the operating system is installed.

To create a volume from an existing disk, complete the following steps:

Important

A “Create from Existing Disk” operation will delete all existing data from the added disk and the data cannot be recovered. It is critical to backup all important data on the added disk before proceeding. However, during the migration process, the data on the source disk is preserved.

After the Intel Matrix Storage Console has been successfully installed and the system has rebooted, click on the Intel Application Accelerator shortcut link (**Start → All Programs → Intel Matrix Storage Manager → Intel Matrix Storage Console**) and the following window will appear:

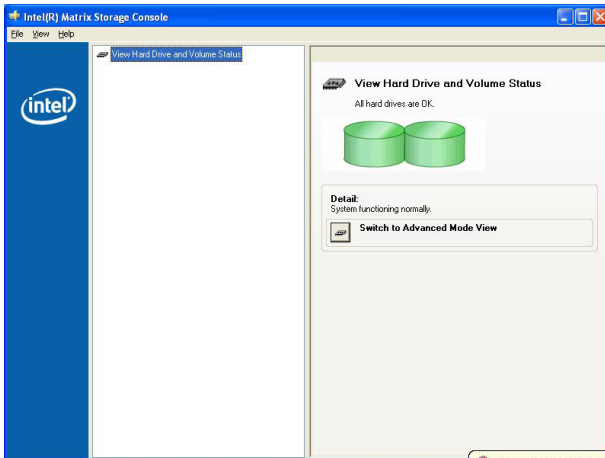

Create RAID Volume from Existing Disk

To create a RAID volume from an existing disk, choose **Action** → **Create RAID Volume from Existing Hard Drive**.

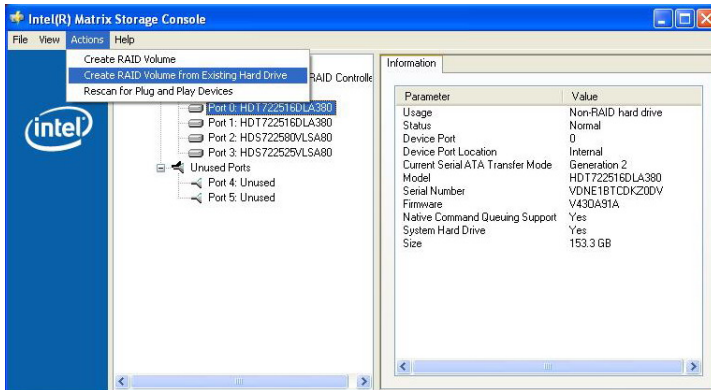

The Create RAID Volume from Existing Hard Drive Wizard pops up to lead you for the following procedure. Click Next to continue.

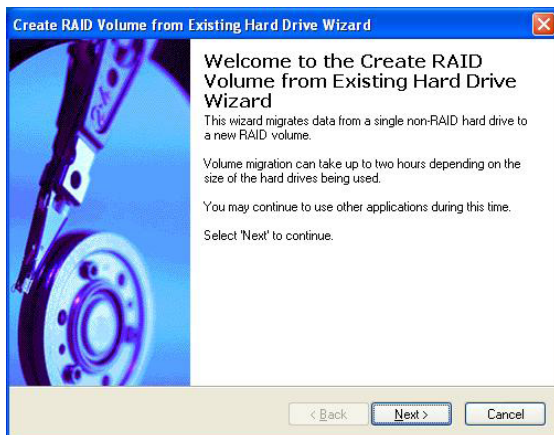

(1) Configure Volume

Here you can configure the new RAID volume by entering the volume name, selecting the RAID level and strip size.

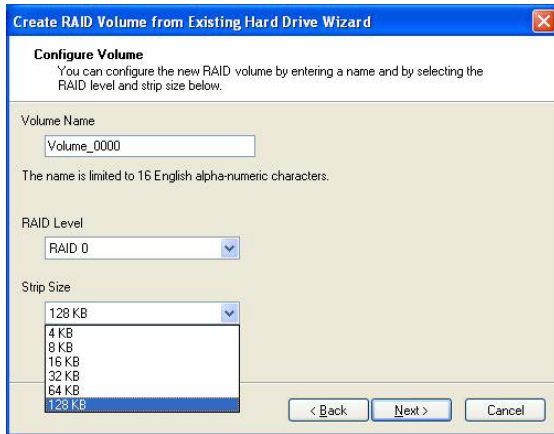

- **RAID Volume Name:**

A desired RAID volume name needs to be typed in where the "Volume_0000" text currently appears above. The RAID volume name has a maximum limit of 16 characters. The RAID volume name must also be in English alphanumeric ASCII characters.

- **RAID Level:**

Select the desired RAID level:

RAID 0 (Performance) :

A volume optimized for performance will allow you to access your data more quickly.

RAID 1 (Redundancy) :

A volume optimized for data redundancy will provide you with a realtime duplicate copy of your data. Note: Only half of the available volume space will be available for data storage.

RAID 5 (Useful) :

RAID 5 can be used on three or more disks, with zero or more spare-disks. The resulting RAID-5 device size will be $(N-1)*S$, where N is the how many drive, S is the size of the smallest drive in the array. If one of the disks fail, all data are still intact. It can rebuild the disk from the parity information. If spare disks are available, reconstruction will begin immediately after the device failure. If two disks fail simultaneously, all data are lost. RAID-5 can survive one disk failure, but not two or more. Both read and write performance usually increase, but can be hard to predict how much. Reads are similar to RAID-0 reads, writes can be either rather expensive (requiring read-in prior to write, in order to be able to calculate the correct parity information), or similar to RAID-1 writes. The write efficiency depends heavily on the amount of

memory in the machine, and the usage pattern of the array. Heavily scattered writes are bound to be more expensive.

RAID 10 (Mirrored Stripes) :

A RAID 1 array of two RAID 0 arrays.

■ **Strip Sizes:**

Select the desired strip size setting. As indicated, the optimal setting is 128KB. Selecting any other option may result in performance degradation. Even though 128KB is the recommended setting for most users, you should choose the strip size value which is best suited to your specific RAID usage model. The most typical strip size settings are:

4KB: For specialized usage models requiring 4KB strips

8KB: For specialized usage models requiring 8KB strips

16KB: Best for sequential transfers

32KB: Good for sequential transfers

64KB: Good general purpose strip size

128KB: Best performance for most desktops and workstations

(2) **Select the source disk**

Then select the source disk that you wish to use and then click "-->" to move it to the "Selected" field. Then click "Next" to continue.

It is very important to note which disk is the source disk (the one containing all of the information to be migrated) and which one is the target disk. On a RAID Ready system, this can be determined by making a note during POST of which port the single disk is attached to.

You can also use the Intel Application Accelerator RAID Edition utility before the second disk is installed to verify the Port and serial number of the drive that contains all the data.

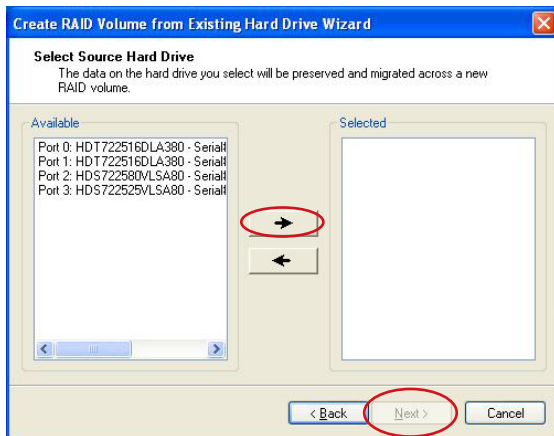

(3) Select Member Hard Drive(s)

Then select the member disk (the target disk) that you wish to use and then click "-->" to move it to the "Selected" field. Then click "Next" to continue.

Please note that the existing data on the selected hard drive(s) will be deleted permanently. Do not forget to back up all the important data before continuing.

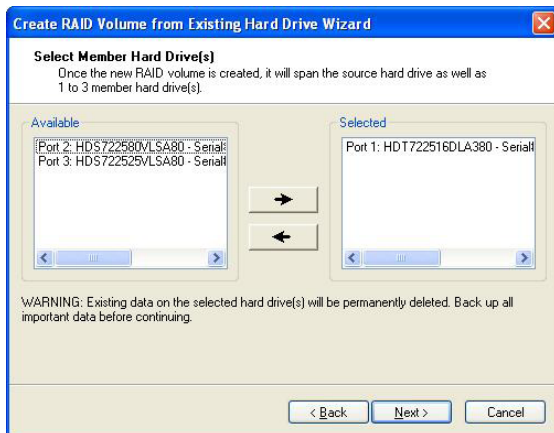
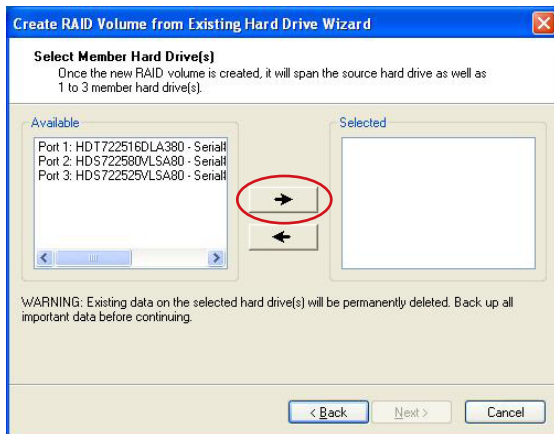

(4) Specify Volume Size

Specify the amount of available array space to be used by the new RAID volume. You may enter the amount in the space or use the slider to specify. It is recommended you use 100% of the available space for the optimized usage. For RAID 0 volume, if you do not specify 100% of the hard drive space, the rest hard drive space will be worked as RAID 1 volume, which is the new technology called Intel Matrix RAID. Then click "Next" to continue.

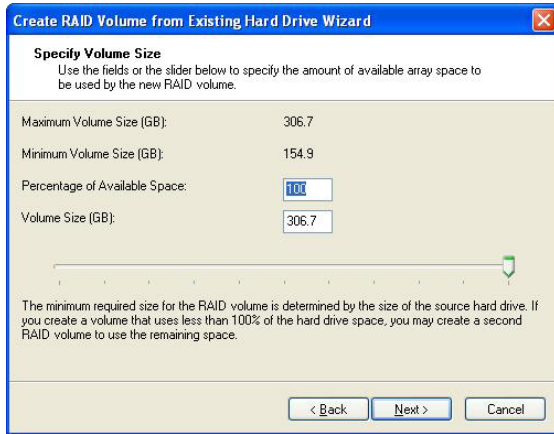

(5) Start Creating RAID Volume from Existing Hard Drive Wizard

Before you continue the procedure of RAID volume creation from existing hard drive, read the dialogue box below carefully. Please note that once you click "Finish", the existing data on the selected hard drive(s) will be deleted permanently and this operation cannot be undone. It is critical that you backup all important data before selecting "Finish" to start the migration process.

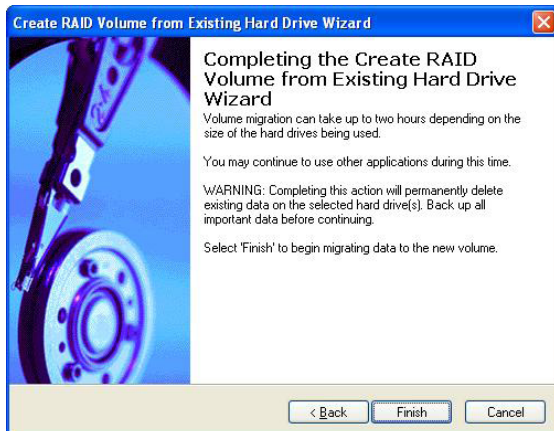

(6) Start Migration

The migration process may take up to two hours to complete depending on the size of the disks being used and the strip size selected. A dialogue window will appear stating that the migration process may take considerable time to complete, meanwhile a popup dialogue at the taskbar will also show the migration status. While you can still continue using your computer during the migration process, once the migration process starts, it cannot be stopped. If the migration process gets interrupted and your system is rebooted for any reason, it will pick up the migration process where it left off. You will be provided with an estimated completion time (the remaining time will depend on your system) once the migration process starts.



The following screen appears if the migration process is completed successfully. Then you have to reboot your system to use the full capacity of the new volume.

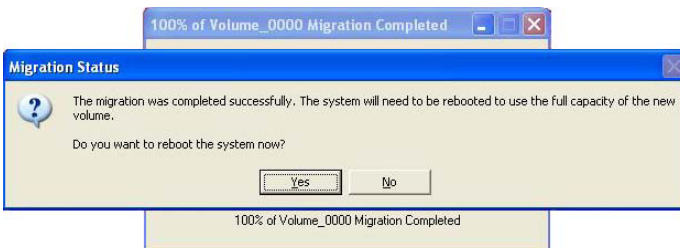

RECOVERY VOLUME CREATION

A recovery volume can be created using either Basic mode or Advanced mode in the Intel Matrix Storage Console.

■ Recovery Volume in Basic Mode Creation

Important

Creating a recovery volume will permanently delete any existing data on the drive selected as the recovery drive. Back up all important data before beginning these steps.

This option may or may not be available depending on your system configuration. If you do not see the option listed, refer to Recovery Volume Creation in Advanced Mode.

To create a recovery volume in Basic mode, use the following steps:

1. Open the Intel Matrix Storage Console. (**Start → All Programs → Intel Matrix Storage Manager → Intel Matrix Storage Console**)
2. Select Protect data using IntelR Rapid Recover Technology.

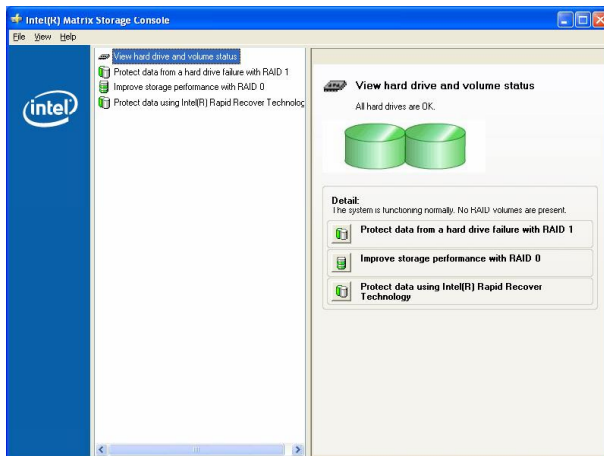

3. Select Yes to confirm volume creation.

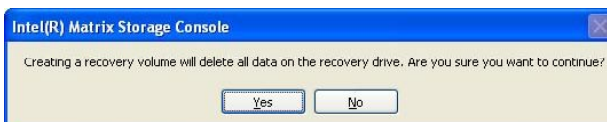

■ Recovery Volume in Advanced Mode Creation

Important

Creating a recovery volume will permanently delete any existing data on the drive selected as the recovery drive. Back up all important data before beginning these steps.

To create a recovery volume in Advanced mode, use the following steps:

1. Open the Intel Matrix Storage Console. (Start --> All Programs --> Intel Matrix Storage Manager --> Intel Matrix Storage Console)
2. Select Advanced Mode in the View menu.
3. Select Create Recovery Volume in the Actions menu.

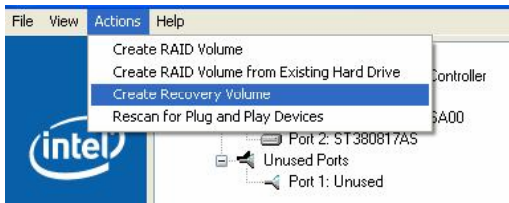

4. Select Next to continue.

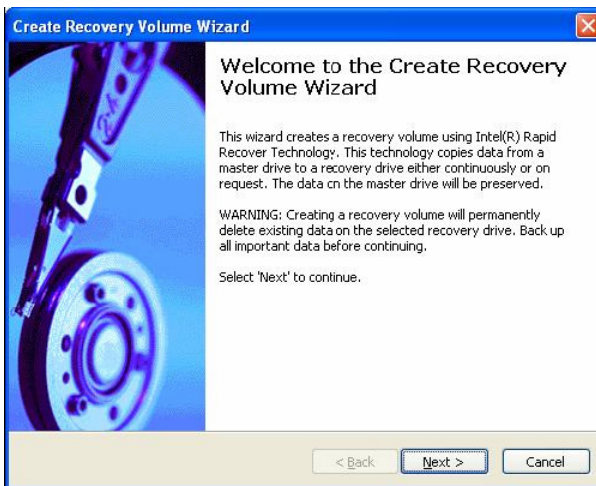

5. Modify the recovery volume name if you wish.
6. Select a hard drive to be used as the master hard drive for the recovery volume.

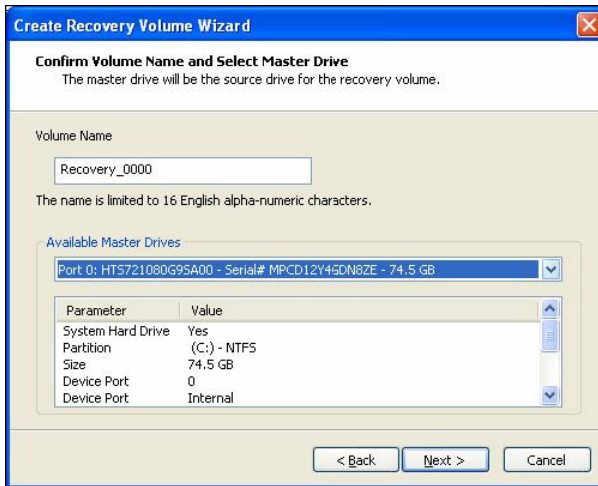

7. Select a hard drive to be used as the recovery hard drive for the recovery volume.

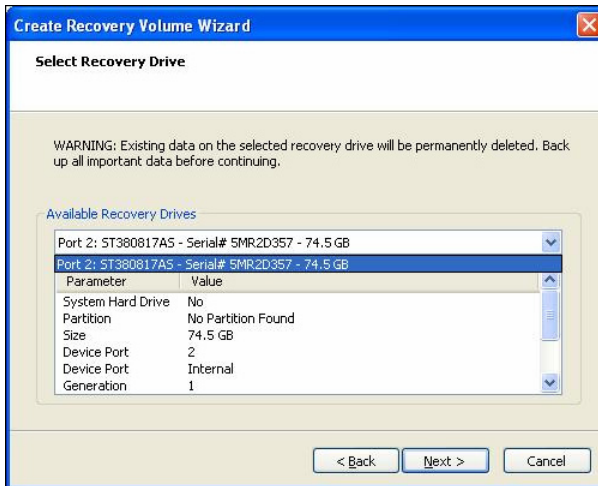

8. Select an update policy.



9. Select Finish to begin recovery volume creation.

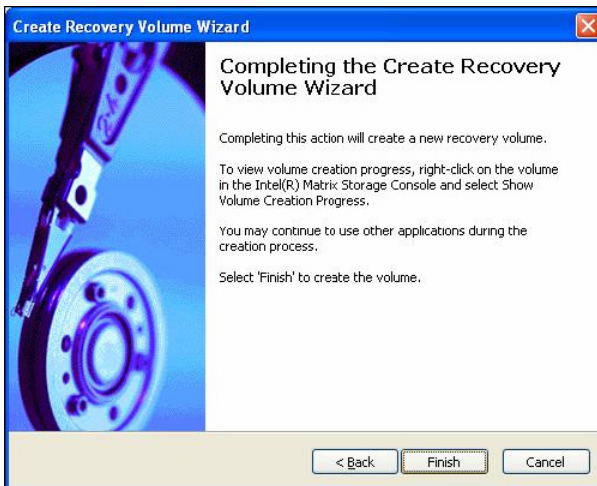

DEGRADED RAID ARRAY

A RAID 1, RAID 5 or RAID 10 volume is reported as degraded when one of its hard drive members fails or is temporarily disconnected, and data mirroring is lost. As a result, the system can only utilize the remaining functional hard drive member. To re-establish data mirroring and restore data redundancy, refer to the procedure below that corresponds to the current situation.

Missing Hard Drive Member

1. Make sure the system is powered off.
2. Reconnect the hard drive.
3. Reboot the system to Windows; the rebuild will occur automatically.

Failed Hard Drive Member

1. Make sure the system is powered off.
2. Replace the failed hard drive with a new one that is of equal or greater capacity.
3. Reboot the system to Intel RAID Option ROM by press <Ctrl> and <I> keys simultaneously during the Power-On Self Test (POST).

```
Intel(R) Matrix Storage Manager option ROM v8.5.0.1013 ICH10R wRAID5
Copyright(C) 2003-08 Intel Corporation. All Rights Reserved.

RAID Volumes
ID Name Level Strip Size Status Bootable
0 Volume0 RAID 10(RAID0+1) 64KB 153.4GB Degraded Yes

Physical Disks::
Port Device Model Serial # Size Type/Status(Vol ID)
0 HDS722580VLSA80 VNRB3EC20549SL 76.7GB Member Disk (0)
1 HDS722580VLSA80 VNRB3EC20559SL 76.7GB Member Disk (0)
2 HDS722580VLSA80 VNRB3EC20569SL 76.7GB Member Disk (0)
3 HDS722580VLSA80 VNRB3EC20589SL 76.7GB Non-RAID Disk

Press <CTRL-I> to enter Configuration Utility..
```

4. Select the port of the destination disk for rebuilding, [ESC]-Exit, and then press ENTER.

```
Intel(R) Matrix Storage Manager option ROM v8.5.0.1013 ICH10R wRAID5
Copyright(C) 2003-08 Intel Corporation. All Rights Reserved.

[ MAIN MENU ]
[ DEGRADED VOLUME DETECTED ]
Degraded volume and disk available for rebuilding detected. Selecting
a disk initiates a rebuild. Rebuild completes in the operating system.

Select the port of the destination disk for rebuilding (ESC to exit):
Port Drive Model Serial # Size
0 HDS722580VLSA80 VNRB3EC20549SL 76.7GB

[ ↑ ↓ ]-Previous/Next [ENTER]-Select [ESC]-Exit

Port Device Model Serial # Size Type/Status(Vol ID)
0 HDS722580VLSA80 VNRB3EC20549SL 76.7GB Member Disk (0)
1 HDS722580VLSA80 VNRB3EC20559SL 76.7GB Member Disk (0)
2 HDS722580VLSA80 VNRB3EC20569SL 76.7GB Member Disk (0)
3 HDS722580VLSA80 VNRB3EC20579SL 76.7GB Non-RAID Disk

[ ↑ ↓ ]Change [ESC]-Previous Menu [ENTER]-Select
```

Intel ICH10R SATA RAID

5. Exit Intel RAID Option ROM, and then reboot to Windows system.
6. When prompted to rebuild the RAID volume, click 'Yes'.
7. The Intel(R) Storage Utility will be launched. Right-click the new hard drive and select 'Rebuild to this Disk'. The 'Rebuild Wizard' will be launched which will guide you through the process of rebuilding to the new hard drive.

